



# downtown specific plan

**Adopted - October 2013**  
**Amended - April 18, 2017**  
**Amended - December 3, 2019**  
**Amended - May 19, 2020**

# contents

## Introduction

The Specific Plan	8
Regional and Local Setting	10
Specific Plan Area	10
Regulatory Setting	10

## Vision and Goals

Vision – The Essence of Downtown	15
Goals	15

## Challenges & Opportunities

Downtown Design Character and Opportunity Sites	25
Land Use	44
Noise	44
Circulation and Mobility	46
Parking	52
Public Utilities	54
Climate Action Plan Implementation	58
Flood Zones	59
Historic Resources	59
Safety	59
Lighting	59

## Land Use and Development - Objectives, Standards and Guidelines

Uses	65
Site Planning	70
General	70
Topography	72
Open Space	72
Public Utilities and Building Services	74
Parking	75
Building Design, Mass and Scale	77
Illustrative Design Examples	80
Colors	85
Building Materials	87
Lighting	88
Signs	92
Landscaping	94

## National Historic Landmark District Design Guidelines

About the Design Guidelines	103
Sustainability - Social, Economic and Environmental Benefits of Historic Preservation	109

# contents

Planning a Preservation Project	112	<b>Financing and Implementation Strategy</b>	
Historical Background of the National Historic Landmark Districts	118	Purpose of the Strategy	249
Development Patterns	124	Development Opportunities	249
Historic Architectural Styles	128	Opportunity Sites	250
Design Guidelines for Historic Properties	133	Public Improvements	251
Miscellaneous Guidelines for both Historic and Non-Historic Properties	154	Implementation Challenges and City Actions	251
Design Guidelines for New Construction	160	<b>Administration</b>	
<b>Circulation, Parking, &amp; Streetscape</b>		Purpose and Intent	259
Traffic Circulation	170	Amendments to the Specific Plan	259
Transit	182	Development Review Process	260
Bicycle Network	184	Implementation	261
Pedestrian Network	185	<b>Definitions</b>	
Streetscape and Plazas	193		
Wayfinding and Public Signs	229		
Sign and Light Poles and Fixtures	233		
Parking	239		
<b>Public Utilities</b>			
Improvement Requirements	245		

This page left intentionally blank

# 01 introduction

This page left intentionally blank

# introduction

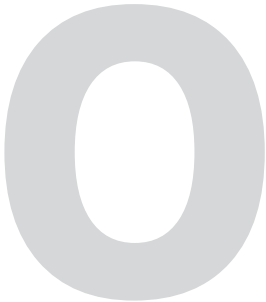

## Introduction

The Downtown Specific Plan (Specific Plan) serves as a guide for future development in the Downtown and East Downtown. The Specific Plan defines the Downtown Specific Plan Planning Area (hereinafter, "Planning Area") as shown in Figure 1. The Planning Area is identified by the General Plan as a "Mixed-Use Village", which is a mix of residences, retail shops, services and jobs in close proximity. With improvements, these areas can be designed to be well served by transit and bicycle routes and have a welcoming pedestrian environment. The General Plan anticipates a development potential of 912 residential units in the Downtown and East Downtown areas. As of adoption of this Specific Plan, six residential units have been constructed.

The Specific Plan, however, assumes that no new water sources will be available for future development within the Planning Area and new development will utilize existing water consistent with Monterey Peninsula Water Management District Rules. As a result, only a limited number of dwelling units and commercial square footage is assumed. Therefore, based on an analysis of existing water credits within the Planning Area, a water-constrained development scenario was created for the Planning Area (50,000 square feet of commercial uses and 260 residential units).

### Increase in Land Uses

<b>Total Commercial</b>	<b>50,000 SF</b>
<b>Residential Units</b>	<b>260</b>

# introduction

## THE SPECIFIC PLAN

The Specific Plan is a unique and effective tool for implementing General Plan Goals, Policies, and Programs. General Plan Goals, Policies and Programs that this Specific Plan strives to implement include:

**Goal b.** *Direct future population growth into mixed-use neighborhoods. The City's goal is to create and nurture mixed-use neighborhoods that: 1) Reduce automobile trips; 2) Improve the quality of the pedestrian experience; 3) Create walkable neighborhoods; 4) Provide more ownership opportunities; 5) Increase the stock of housing affordable to Monterey's work force; 6) Require high-quality design to complement Monterey's image; and 7) Improve neighborhood-oriented services.*

**Policy b.1.** *Create design concepts, development guidelines, and capital improvement programs for mixed-use neighborhoods. Emphasize attractive pedestrian, bicycle and transit access, which may require improved sidewalks, crosswalks, and various public way improvements. The City encourages owner occupied units, innovative site planning and tailoring the design and density to fit with the neighborhood. Mixed-use developments are encouraged to be attractive in design, hide parking from the street, create a pleasant pedestrian environment, and provide a transition into the residential zones through good site planning and design.*

**Program b.1.1.** *Develop Mixed-Use Neighborhood Guidelines for the East Downtown area in the Specific Plan. The intent of the guidelines would be to provide policy and illustrated design concepts that lead to mixed-use or apartment/condominium housing for a wide range of incomes to encourage customers and employees to live near downtown. The plan will be to capitalize on the access to alternative transportation modes, Lake El Estero, the waterfront, downtown, and the employment center of Monterey. Shared parking, including the potential for public parking, is encouraged to minimize the amount of land dedicated to parking.*

**“Direct future population growth into mixed-use neighborhoods.”**

**Program b.1.2.** *Develop Mixed-Use Neighborhood Guidelines for the Downtown area in the Specific Plan. The goal is to maintain the downtown as the City center. The intent of the guidelines would be to provide policy and illustrated design concepts that maintain the pedestrian-friendly and historic environment with retail on the ground floor and housing or other uses above. Encouraged transportation modes include the shuttle, walking, and bicycles. Shared parking, including the use of private parking spaces when not needed for their primary use, is encouraged to minimize the amount of land dedicated to parking. Guidelines should address building height. Height of new construction should respect neighboring historic buildings.*



# introduction

**Goal c.** *Provide a safe, efficient, well-maintained, and environmentally sound roadway system that supports equality of choice among all modes of transportation.*

**Goal f.** *Provide an attractive and convenient transit service for Monterey citizens, especially those in the community who cannot or choose not to own a private automobile.*

**Policy g.1.** *Provide pedestrian-friendly environments in the commercial business districts to extend the time spent in the commercial business districts and enhance the overall shopping experience.*

**Policy g.2.** *Do not allow auto-oriented level-of-service standards to negatively affect the shopping experience in commercial business districts.*

*“Provide a safe, efficient, well-maintained, and environmentally sound roadway system that supports equality of choice among all modes of transportation.”*

This Specific Plan replaces the Downtown Area Plan with a more comprehensive strategy for the enhancement of this commercial area as mixed-use neighborhood. The Specific Plan provides tools beyond the capabilities of the Area Plan, such as area-specific development standards and design

guidelines, and an inventory of existing and proposed improvements to the neighborhood’s infrastructure. The Financing and Implementation chapter identifies potential funding sources for proposed rights-of way improvements. This chapter also recommends a strategy for obtaining the necessary funding to meet the project recommendations.

Under California law, local governments can use specific plans as tools to plan for needed revitalization and change, both in existing neighborhoods and new development areas. Specific plans provide greater planning and design guidance than can be included in a General Plan, and they allow local governments the ability to address complex land ownership patterns and infrastructure needs. Specific plans can jump-start new development in depressed areas, and can ensure new development is high quality.

The planning process for the Specific Plan included several community meetings. A Planning Commission Ad Hoc Committee also reviewed and commented on the plan during its development. The Planning Commission hosted numerous public meetings on key components of the Specific Plan including circulation, parking, streetscape and urban design issues.

# introduction

## REGIONAL AND LOCAL SETTING

The Planning Area is located in the City of Monterey, an ocean side community that is recognized nationally for its historic setting. The Monterey Bay National Marine Sanctuary borders the Downtown and offers a variety of boating, whale watching and kayaking opportunities. Monterey's resident population is approximately 30,000 persons. It is a frequent and favorite destination of San Francisco Bay residents.

## SPECIFIC PLAN AREA

The Planning Area consists of approximately 106 acres. The General Plan recognizes the study area as two distinct mixed-use areas – Downtown and East Downtown. The Downtown area is currently home to a commercial core, historic resources, educational institutions as well as some public/semi-public property. The East Downtown area is characterized by mainly residential land uses with some small scale office buildings.

## REGULATORY SETTING

Similar to a General Plan, the contents of a specific plan are to a degree defined by State law. The required contents for a specific plan include the following:

- Text and diagrams showing the distribution, location and extent of all land uses, including open space.
- Proposed distribution, location, extent and intensity of major components of public and private transportation, sewage, water,



drainage, solid waste disposal, energy and other essential facilities needed to support the land uses.

- Standards and guidelines for development, and standards for the conservation, development and utilization of natural resources, where applicable.
- Program of implementation measures including regulations, programs, public works projects and financing measures.
- Statement of Specific Plan's relationship to the General Plan.

# introduction

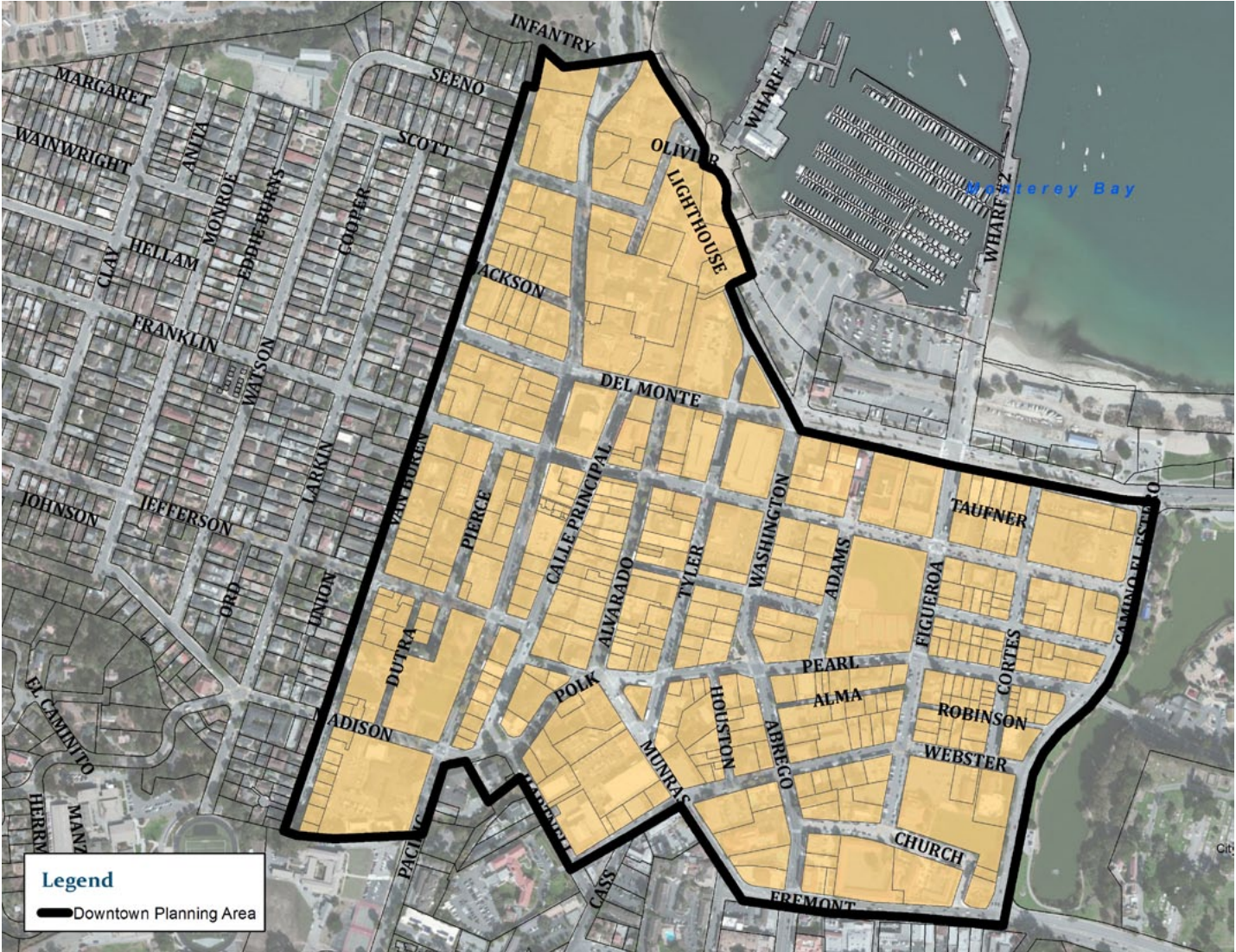
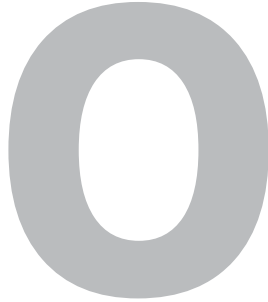

Figure 1: Downtown Specific Plan Planning Area

This page left intentionally blank

# 02 vision & goals

This page left intentionally blank



## Vision and Goals

Early in the process of creating a specific plan for the three mixed-use areas of the City, community meetings focused on identifying a specific vision and set of goals for each mixed-use neighborhood. The vision and goals provided the framework for developing objectives, standards and guidelines to meet the vision and goals. A truly successful specific plan will effectively meet the vision and goals as development occurs in each of the mixed-use neighborhoods.

### VISION – THE ESSENCE OF DOWNTOWN

The vision for Downtown Monterey is to have an exciting, constantly changing hub of activity in a clean, safe, pedestrian environment with a unique identity that embraces the colonial heritage and historic architecture, with appropriate streetscape, public gathering places, signs and gateways. The Downtown will provide a mix of services, special events, and retail establishments of local, regional and national character which will be attractive to visitors and will be a place that all residents will visit frequently.

### GOALS

#### Create Comprehensive Transportation and Parking Plan.

- Goal 1.a. Create a seamless transportation plan that integrates the Downtown network with the surrounding area.
- Goal 1.b. Eliminate the confusing street names and complicated downtown network of one-way streets while providing for easy pass-through from west to east, and ease of access for bicycles.

**General Plan Goal:**  
*“Direct future population growth into mixed-use neighborhoods.” The City’s goal is to create and nurture mixed-use neighborhoods that: 1) Reduce automobile trips; 2) Improve the quality of the pedestrian experience; 3) Create walkable neighborhoods; 4) Provide more ownership opportunities; 5) Increase the stock of housing affordable to Monterey’s work force; 6) Require high-quality design to complement Monterey’s image; and 7) Improve neighborhood-oriented services.*

- Goal 1.c. Develop and implement pedestrian, transit (bus, trolley and shuttle), and bicycle friendly strategies which will encourage people to get out of their cars and walk the Downtown after parking in parking structures around the periphery of the Downtown.

# vision & goals

Goal 1.d. Create a continuous pedestrian/transit concourse from Wharf # 1 to Polk Street through Custom House Plaza and along Alvarado Street.





# vision & goals

## **Create a Mixed-Use Neighborhood.**

Goal 2.a. Encourage property owners to construct residential units in the Planning Area.

## **Ensure an Attractive Inventory of Business Establishments.**

Goal 3.a. Develop and define an inventory of desirable and high quality business activities which are compatible with the Vision and which will attract visitors and encourage pedestrians to use the Downtown.

Goal 3.b. Create incentives for property owners to build for and attract suitable businesses.

## **Downtown Design Character.**

Goal 4.a. Preserve the Downtown architectural character that reflects “Old Monterey” including its adobes, early twentieth century architecture and landmark resources.

Goal 4.b. Promote new structures and new/improved open spaces in the Downtown that complement the City’s strong architectural heritage with appropriately designed mass, scale, rhythm, and siting.

Goal 4.c. Begin developing a branding strategy that incorporates music, art and history and a high quality contemporary, yet eclectic, design aesthetic.

## **Develop a Financing Plan.**

Goal 5.a. Develop financing alternatives to

implement the Specific Plan infrastructure improvements which address the cost of all municipal improvements and services, consistent with the Vision and Goals. The financing alternatives should include but not be limited to, public/private ventures, private development, grants, special assessment districts, and parking and fee strategies.

## **Develop Community and Industry Standards.**

Goal 6.a. Assemble as much empirical information, fact, and evidence as is available to provide a firm foundation for the decisions and plans to implement these Goals.

Goal 6.b. Communicate and educate the citizens, as well as the “stake-holders”, as to the possible means and existing examples of similar initiatives to revitalize the downtown commercial district.

This page left intentionally blank

# 03 concept plan

This page left intentionally blank

# concept plan

Alvarado Mall Improvements



Custom House Plaza Improvements



Sidewalk Seating



Simoneau Plaza Improvements



03 Concept Plan

Figure 2: Concept Plan

This page left intentionally blank

# 04 challenges & opportunities

This page left intentionally blank



# O

## Challenges & Opportunities

### DOWNTOWN DESIGN CHARACTER AND OPPORTUNITY SITES

Everywhere you look in Downtown Monterey there are remnants of other times and other lives, from the Spanish influence of the City's founders to the early twentieth century business district. It is a place that visitors seek to experience and residents enjoy calling home.

Downtown Monterey's future changed when a major structural fire caused significant damage along Alvarado Street, Monterey's main street. The resulting gaping hole and community concern about the "worn" appearance of the Downtown spurred the City to initiate change. These issues reinforced the need to implement the City's 2005 General Plan that envisions a pedestrian-friendly, active, and mixed-use Downtown.

The City of Monterey City Council reprioritized its work program to focus on a Downtown revitalization strategy. This momentum to revitalize the Downtown redirected City efforts to create a Downtown Specific Plan. The Specific Plan creates a vision for Downtown Monterey and an implementation strategy that capitalizes on public/private partnerships to achieve its goals.

The Specific Plan contains several districts that have developed over time, and merit distinct design policies, objectives, standards, and guidelines that address the unique characteristics.

# challenges & opportunities

- Alvarado District
- East Village District
- Pearl District
- Public Recreation District
- National Historic Landmark District
- Heritage District
- Island of Adobes
- Pierce District
- Royal Presidio District

The following section provides an overview of each district and opportunity sites within that district.



# challenges & opportunities

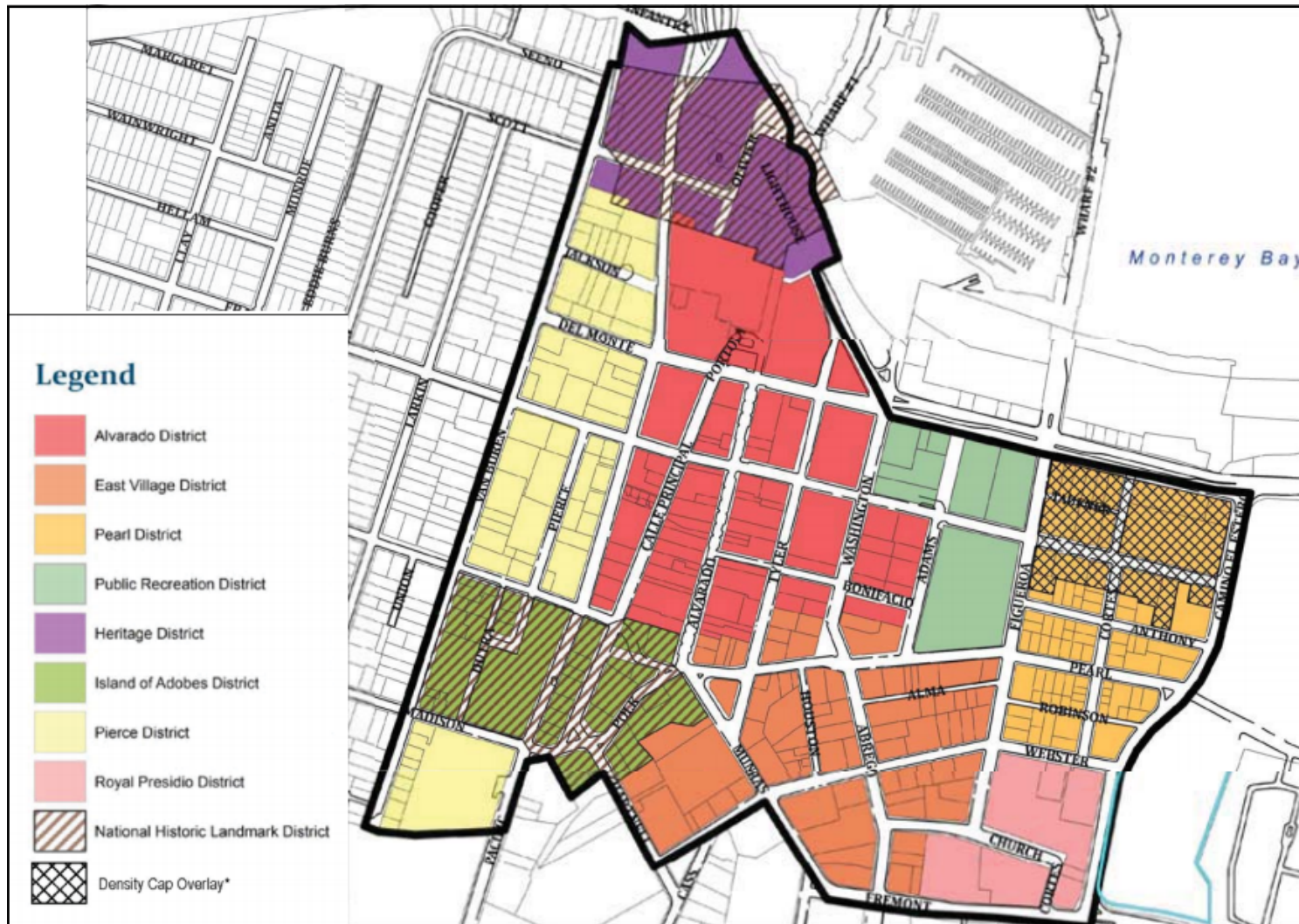

Figure 3: Character Areas

# challenges & opportunities

## Catalyst and Opportunity Sites

The Specific Plan area includes both vacant and underutilized lots with the capacity to contribute to the City's affordable housing goals. Most of the City's residential districts are built out and provide few opportunities for the construction of new affordable housing. Because the City of Monterey has a limited water supply, most of the City's recent affordable housing development has resulted from the redevelopment of underutilized sites in the commercial neighborhoods where high water uses are replaced with mixed use projects.

The first exercise in identifying opportunity sites was to identify ownership patterns throughout the Planning Area. The second step identified contiguous sites that are under a single ownership that could share water resources across property lines. By overlaying those properties identified as underdeveloped and hosting existing uses with water, opportunity sites emerge

Opportunity sites are defined as vacant and underutilized properties that appear ripe for development. Factors contributing to the identification of opportunity sites include: ownership patterns, available water credits, building condition and location.

Figure 4 identifies sites that are most likely to develop, given the Monterey Peninsula's water constraints. These projects will be key in the early implementation of the Specific Plan vision. Six (6) sites possess all

of the following characteristics that would support immediate or future development:

- Common ownership patterns
- Underdeveloped sites
- Host existing uses with water

These sites are the most likely to redevelop first and are considered to be potential catalyst sites.

# challenges & opportunities



Figure 4: Catalyst Sites

# challenges & opportunities

## Alvarado District Overview

The Alvarado District is generally bounded by Pacific Street to the west, Adams Street to the east, Pearl/Jefferson Streets to the south and Custom House Plaza to the north. The District contains a mix of building types, but is substantially influenced by traditional commercial buildings. These are primarily rectangular buildings with one to four stories.

The primary entrances of many buildings are oriented toward the street and are typically a part of the storefront system. Several roof forms are visible including flat, hip and gable roofs. A continuous street facade is apparent, although broken in some areas where a paséo, small plaza or surface lot exists.

## Challenges

A distinguishing feature of this area is the difference in elevation between Pacific Street, Calle Principal and Alvarado Street. Wherever one storefront occurs at one height the parallel street has a one floor difference. This has resulted in areas where Calle Principal (an approximate 8'-10' grade above Alvarado Street) has been treated as a building back side. Double-fronted buildings would achieve a more pedestrian-friendly environment.



Alvarado District

# challenges & opportunities

The Alvarado District contains 13 vacant and 25 underutilized lots. The most prominent of these sites resulted from a structural fire and other sites were originally developed with a building frontage only on Alvarado Street. This development pattern creates opportunity sites along Calle Principal and Tyler Streets. The figure below identifies the location of the catalyst and opportunity sites within the Alvarado District, which are described as follows:

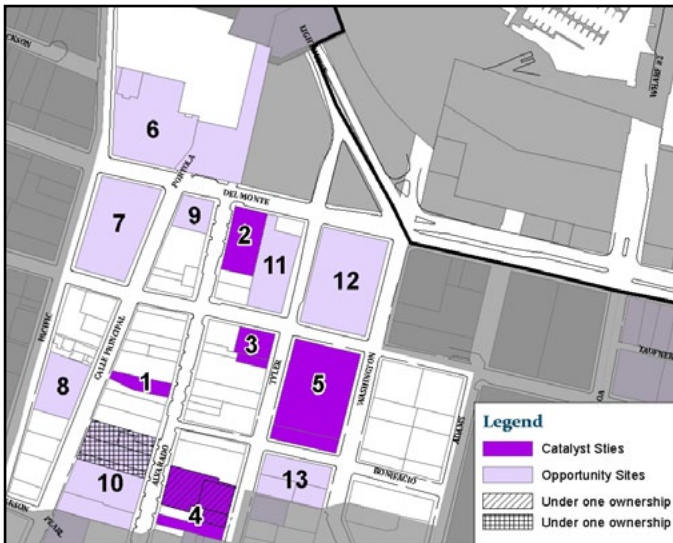

Catalyst and Opportunity Sites

## Catalyst Sites

**Site #1** currently contains a vacant building. The building was previously a theater but was vacated. Plans have been recently approved to renovate the building site.



**Site#2** is a building with a large water credit. The redevelopment of the site into a mixed-use building would greatly improve a key corner in the Alvarado District.



# challenges & opportunities

**Site # 3** currently houses a one-story commercial building. The site has a large water credit that could contribute to its redevelopment. Redevelopment of this site should also explore including the adjacent site at the corner of Franklin and Alvarado. Because this site lacks sufficient water credits, its reuse could benefit from a water credit transfer from the adjacent site. Redevelopment of the entire Franklin Street frontage would benefit from gaining street frontage and exposure on Alvarado Street.



**Site #4** includes four lots of record and .74 acres. Three parcels are commonly owned. In 2008, the City reserved water for the three parcels under common ownership. Because the fourth parcel is a double frontage parcel, it should be included in a development plan if possible.



**Site #5** is desirable due to its size, location, common ownership, and available water. It encompasses an entire city block (63,290 square feet) and has frontages on four streets.



# challenges & opportunities

## Opportunity Sites

**Site #6** contains the Portola Plaza which frames the entrance to a major hotel and conference center. As currently designed, this plaza seems detached from the Downtown. A concept for the redesign of the plaza is introduced in Chapter 6. The new design will compliment the functionality of the Conference Center.



**Site #7** contains a multi-story hotel. Currently, large walls front several streets including Pacific, Franklin and Del Monte. The introduction of commercial storefronts or decorative treatments along the building's edge would create a more active street.



**Site #8** is currently developed with a parking garage. The site is located across the street from a major educational center with a large student population. The infill of new uses along the empty street frontage would increase its vitality and interest to the pedestrian.



**Site #9** is currently developed with a two-story commercial building. The site location is desirable because it is the future entry point to Alvarado Street from Del Monte Avenue. The site is 10,464 square feet (.24 acres) and can accommodate a much larger building when considering the development potential and surrounding context.





# challenges & opportunities

**Site #10** encompasses 1.75 acres. Of this acreage, .60 acres (four parcels) have a common owner, increasing the opportunity to combine parcels into a larger developable site. This site also includes the City-owned parcel that is located at the corner of Calle Principal and Pearl Street in the Island of Adobes District. Development proposals that include this parcel should capitalize upon the site's proximity to significant historic buildings including the Larkin House, Alvarado Adobe and Cooper Molera complex. An additional consideration is that this site is adjacent to the two-story commercial building at 482 Alvarado Street, which has been previously identified as a historic structure.



**Sites #11 and #12** are City parking structures. Surrounding street frontages would benefit from the addition of commercial storefronts or artwork along the buildings' edges to create a more active Downtown.



**Site #13** includes three lots of record and one adjacent lot in the East Village District totaling 34,587 square feet. The area is adjacent to Site #5 and in terms of location and existing building size qualifies as an opportunity site.



# challenges & opportunities

## East Village District

### Overview

The East Village District is generally bounded by Fremont Street to the south, Figueroa Street to the east, Hartnell Street to the west and Pearl Street to the north. The District contains several building types which result in a varied streetscape. This mix supports traditional retail, office, service commercial residential uses. Building forms are rectangular and typically one to two stories. In general, the primary entrance is oriented to the street. Several traditional roof forms are visible including flat, hip and gable roofs.

### Challenges

The primary challenges are smaller lot sizes and multiple ownerships.



East Village District

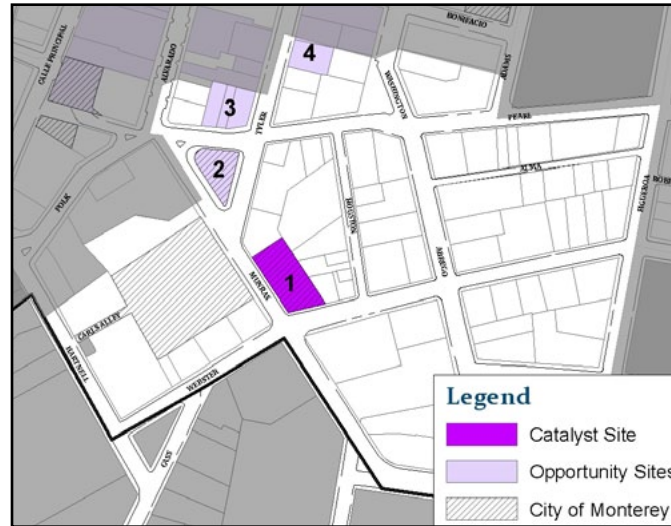

Catalyst and Opportunity Sites

The figure above identifies the location of the catalyst and opportunity sites within the East Village District, which are described as follows:

### Catalyst Site

**Site #1** is owned by the City of Monterey. In 2012, the City approved plans for a mixed use development at the site.



# challenges & opportunities

## Opportunity Sites

**Site #2** is owned by the City of Monterey and is the current location of the Monterey Salinas Transit (MST) transit center. As part of the Specific Plan process, the City is working with Monterey Salinas Transit to relocate the transit center to Washington Street between Franklin Street and Del Monte Avenue. Chapter 6 includes a new design for this plaza, which will serve as a beautiful gateway to the Alvarado District.



**Site #3** is located at the corner of Pearl and Tyler Streets and is currently underdeveloped, but lacks water. However, the site could be incorporated into a larger development project on the adjacent opportunity site.



**Site #4** is a parking lot and could accommodate infill development if water were available.



# challenges & opportunities

## Pearl District

### Overview

The Pearl District is bounded by Camino El Estero to the east, Webster Street to the south, Figueroa Street to the west, and Del Monte Avenue to the north. It contains a mix of building types. The commercial buildings facing Del Monte Avenue include a mix of one and two story structures. Traditional single-family residential buildings dominate the remainder of the Planning Area. Building forms are rectangular and one to two stories. The primary entrance is oriented to the street and protected by a covered porch. Roof forms include hip and gable types. Where commercial and office buildings occur, they are on larger lots and are primarily two stories; these include some flat-roofed structures.

Distinguishing features in the Pearl District are nearby recreation opportunities and open spaces. Today, there exists a lower lot coverage ratio than in the East Village District

### Challenges

The Pearl District contains small lots and narrow streets. New development will most likely need to assemble lots and creatively design site access. The District is also located at a relatively low elevation and flood risk maps indicate that the area may be subject to inundation. (Refer to Figure 7)



*Pearl District*

# challenges & opportunities

## Opportunities

Due to the existing low density development, the Pearl District provides an opportunity to build new housing at higher densities.

The District has a large opportunity area encompassing approximately six blocks as shown in the lower right figure. Water credits exist in the area based on the commercial uses on Del Monte Avenue and the fast food restaurant at the corner of Del Monte Avenue and Camino El Estero. The opportunity area includes 42 parcels. Of these parcels, 17 are commonly owned. Land assembly will be a challenge in this area.



*Pearl Street Bungalows*

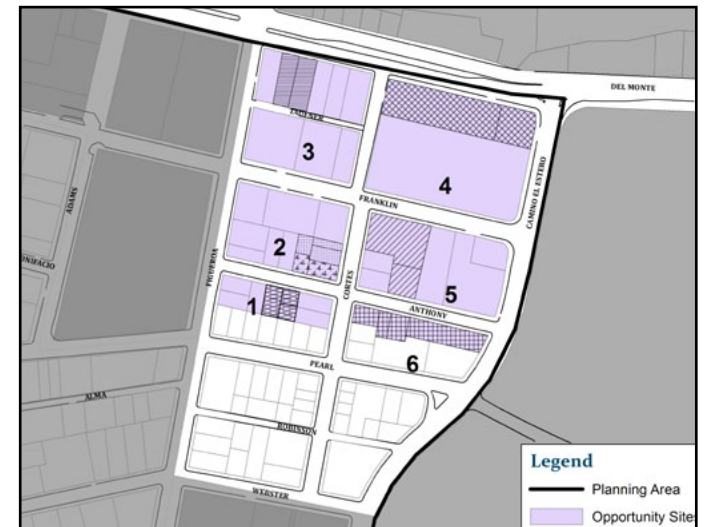

*Opportunity Sites*

# challenges & opportunities

## Public Recreation District

### Overview

The Planning Area contains a large public-owned recreational area that includes the Monterey Sports Center and Jacks Park.

### Challenges

The recreation area is a popular community facility. The facility parking demands vary depending on the ball games scheduled at Jacks Park.

### Opportunities

Several recreational-oriented businesses have opened adjacent to the Monterey Sports Center and Jacks Park. There are additional business opportunities that could capitalize on the local, regional and national events.



*Public Recreation District*



*Jacks Park*



*Monterey Sports Center*

# challenges & opportunities

## National Historic Landmark, Heritage and Island of Adobes Districts

### Overview

The National Park Service recognizes and designates nationally significant historic buildings and districts in the United States. A National Historic Landmark District (NHLD) was designated by the Park Service in 1970 and contains a northern and southern area. The northern area (Heritage District) surrounds the Custom House Plaza near the waterfront and the southern area (Island of Adobes) is near the intersection of Polk and Hartnell Streets.

The Heritage District contains several historic resources including the Custom House, Pacific House, Casa del Oro, First Theater, First Brick House and Whaling Station.

The Island of Adobes District includes several adobe buildings including the First Federal Courthouse, Casa Gutierrez, House of Four Winds, Larkin House, and Stokes Adobe. Colton Hall, the location of the 1849 California Constitutional Convention, is a prominent landmark in this area.



*The Custom House*



*National Historic Landmark District*



*Heritage District*

# challenges & opportunities

## Challenges

The NHLD is nationally significant. During the public workshops, the community continually identified this area as unique and a special place. However, the City's historic areas are underutilized.

Monterey's historic resources need to "come alive" and be a focal point for Historic Monterey.



Island of Adobes



Island of Adobes - Example

There are tremendous opportunities to enhance "programming" for the City's historic areas. As part of the programming, commercial uses fronting Custom House Plaza are encouraged. The figure below identifies the location of the opportunity sites within the NHLD, which are described as follows:

## Opportunity Sites

**Site # 1** is owned by the City of Monterey and is currently a museum.

**Site # 2** is owned by the State of California and the location of the Custom House Plaza and a green lawn.

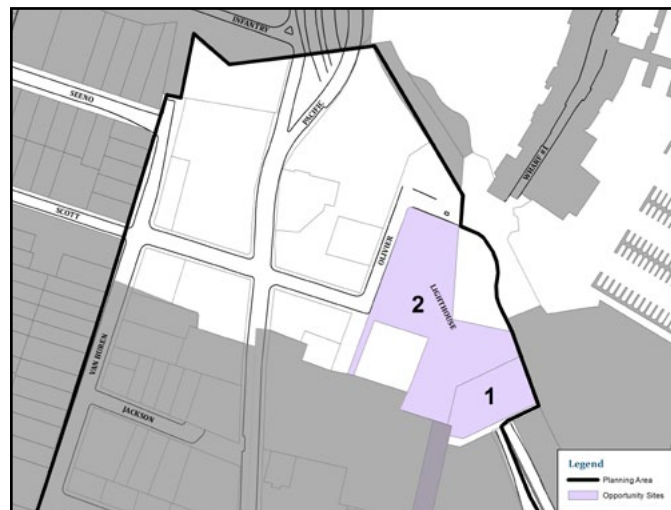

Opportunity Sites



# challenges & opportunities

## Pierce District

### Overview

The Pierce District can be generally described as the area between Pacific and Van Buren Streets.

The City's Civic Center campus is located in this area and houses the City's administrative offices, police and fire stations, public parking, and large open spaces.

The Monterey Institute of International Studies Campus (MIIS) is centrally located in the area. The area also includes a number of residential structures.

### Challenges

The police and fire stations are bordered by a block of residential buildings along Van Buren Street to the west and a potential trail system to the south. Development within this area will need to address this transition between residential and civic uses and the future trail.



*Pierce District*



*Pierce District - Example*

# challenges & opportunities

## Opportunities

The area provides key civic and safety resources for the Downtown. The MIIS Campus energizes the area with students and faculty. This is a key population group in the Planning Area.

The figure below identifies the location of the opportunity sites within the Pierce District, which are described as follows:



Opportunity Sites

**Site #1** consists of a row of small lots owned by the City of Monterey on the east side of Van Buren Street adjacent to the City's Police and Fire Stations. The City has been investigating the possibility of additional housing on these lots to augment the community's housing supply and address the transition from residential to public uses.



**Site #2** consists of the City of Monterey's Police and Fire Stations. These facilities will require updating as community services continue to evolve. A current trend is consolidation of services on the peninsula to reduce costs.



# challenges & opportunities

## Royal Presidio District

### Overview

The Royal Presidio District is located at the corner of Fremont and Camino El Estero. The district includes nationally significant historic resources including the Royal Presidio Chapel and George Turner Marsh building. These key historic resources were recently restored and are memorable features.

The area is also known to contain archaeological resources.

### Challenges

The area includes significant historic and archaeological resources. The Royal Presidio Chapel is the only extant building from the Spanish era in Monterey. Any new development will need to be sensitive to these issues.

### Opportunities

The Royal Presidio Chapel and George Turner Marsh buildings were recently restored. There is still an opportunity to visually improve the properties located between Church and Webster Streets.



*Royal Presidio District*



*Royal Presidio District - Example*

# challenges & opportunities

## LAND USE

Historically, Downtown Monterey developed as the commercial center for the Monterey Peninsula. Its role as an economic center has diminished over the years due to increasing economic development in other communities.

Sales and hotel tax data indicated that Downtown Monterey revenues have continued to decline.

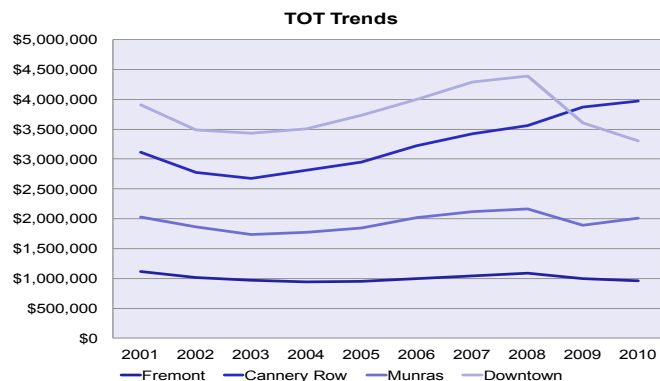
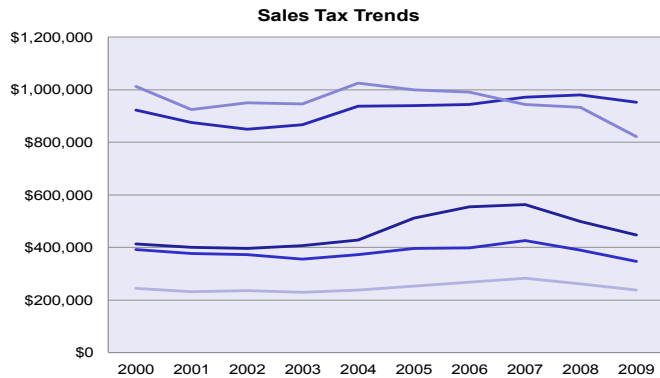

## NOISE

The General Plan sets noise thresholds for new development. Noise is also addressed in the required performance standards in City Code Section 38-111. The General Plan also identifies Pacific Street, Del Monte Avenue, Munras/Abrego/Washington Streets, and Fremont Street as being exposed to higher noise levels. Additionally, Downtown Monterey has an active nightlife. Evening venues that host live entertainment can be noisy. The approval process for new residential development needs to evaluate its setting and incorporate noise attenuation in the project design as appropriate.

### Airport Overflight Zones

A portion of the Planning Area is subject to the Monterey Peninsula Airport Comprehensive Land Use Plan (CLUP) (See Figure 5). The CLUP contains policies and maps that define affected areas and various levels of regulation that apply to those areas. The majority of these regulations affect sites outside of the Planning Area. CLUP policies that apply to the affected portion of the Planning Area include:

- Public use facilities and institutions such as schools are incompatible and shall not be located within the 65 and greater CNEL noise contour area or locate within two miles of airport runway. (Figure #4 of the CLUP)
- Public use facilities and institutions such as schools are incompatible and shall not locate within the 2-mile buffer area.
- Structures shall not penetrate the FAR PART

# challenges & opportunities

77 imaginary surfaces without either FAA or ALUC permission as it relates to lighting and marking.

- Uses which promote hazards to air navigation such as electrical interference, high intensity lighting, bird attractions, smoke or glare shall be reviewed by the ALUC and, where necessary, prohibited.

No sections of the Downtown are within the 65 CNEL or greater noise contour area. However, a relatively small part of the Downtown area is located within the 2-mile buffer. The CLUP states that public use facilities and institutions such as schools are incompatible and shall not locate within the 2-mile buffer area. In regards to the “imaginary surfaces” and air navigation hazards, facilities will be required to comply with this requirement.

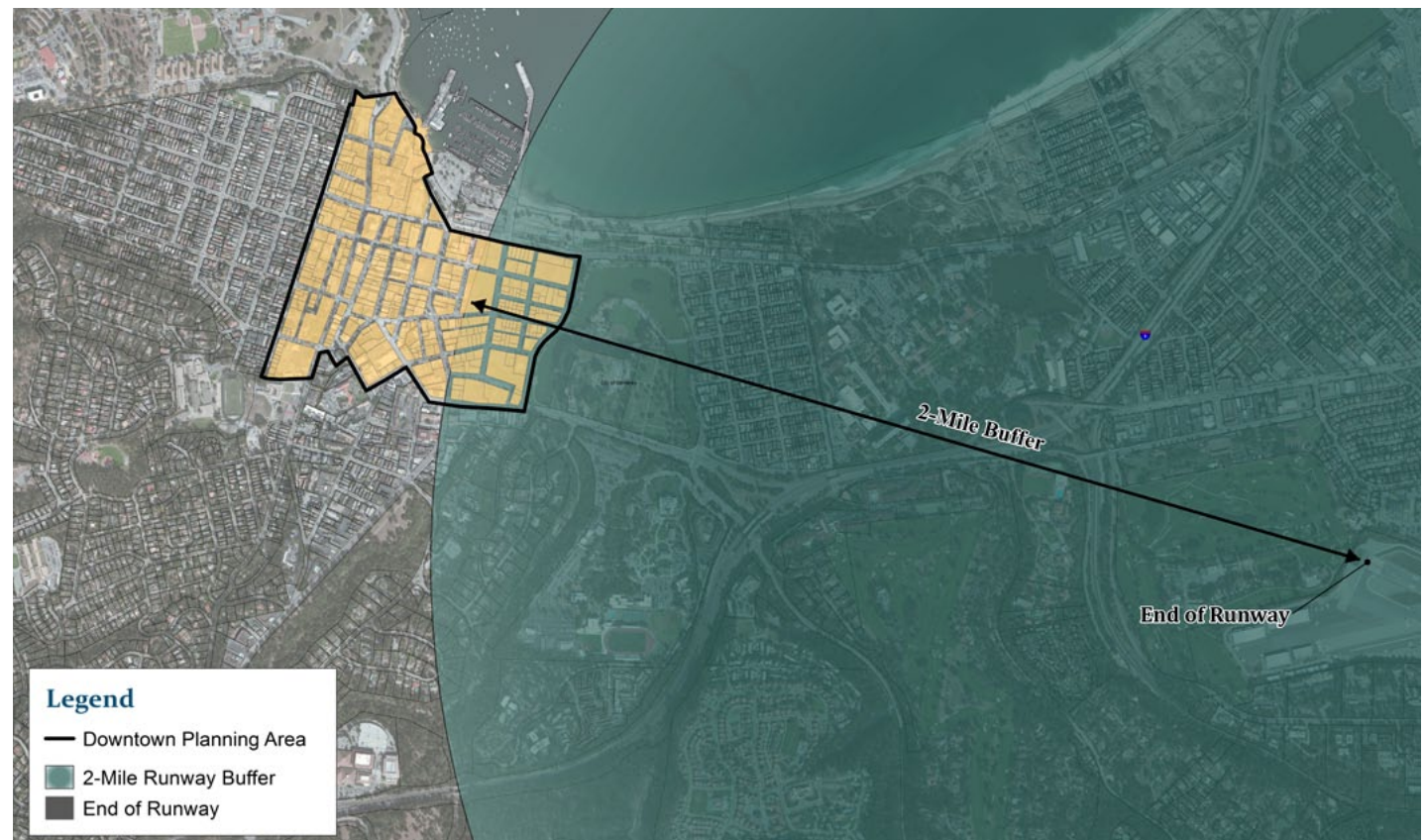

Figure 5: Airport Map

# challenges & opportunities

## CIRCULATION AND MOBILITY

### Streets

The Downtown has been described as a confusing maze of one-way streets. The Specific Plan proposes that the majority of Downtown's one-way streets be converted to two-way to create more predictable access into the Planning Area.

Figure 6 shows the downtown street network. Del Monte Avenue and Fremont Street connect to Highway One, carry large traffic volumes and are classified as major arterials. Minor arterials within the Planning Area include Pacific, Franklin, Munras, Washington, Abrego, and a small portion of Del Monte Avenue. Franklin Street provides access to the Army's Defense Language Institute and serves as the primary east-west connection through Downtown.

### Transit Service

Monterey/Salinas Transit currently provides bus service through the Planning Area. Bus stops are located at Simoneau Plaza near the intersection of Munras and Alvarado and between the parking garages located on Tyler Street. Construction of improvements for a bus rapid transit (BRT) line through Downtown are underway. The BRT line will connect the Edgewater Shopping Center in Sand City with Cannery Row via North Fremont Street and Downtown Monterey. A key objective is to improve bus service between the mixed-use areas with a minimum of 15 minute headways. Additionally, various options are being explored for the

Del Monte Corridor including a bus rapid transit system or light rail.

### Bicycle Circulation

The City's Multi-Modal Mobility Plan (MMMP) designates bike routes within the Downtown. Current bikeway deficiencies include a circuitous route around Downtown, instead of through the heart of Downtown, and missing links to the Recreation Trail. Key future facilities include: a bike boulevard along Pearl and Jefferson Streets and a Class II bikeway on Washington Street.

### Pedestrians

The Downtown street rights of way include approximately eight - eleven foot sidewalks on Alvarado Street and varying widths in the remaining portion of the Planning Area. The sidewalks along the corridor contain impediments to safe pedestrian access such as utility poles, newspaper racks, lifted pavement, steep grades, and narrow passage.

The Specific Plan will address these impediments through creating areas of expanded sidewalk for pedestrian refuge, outdoor dining areas, bus stops, and improved street furniture. The proposed improvements would create clear and unimpeded pedestrian access.

# challenges & opportunities

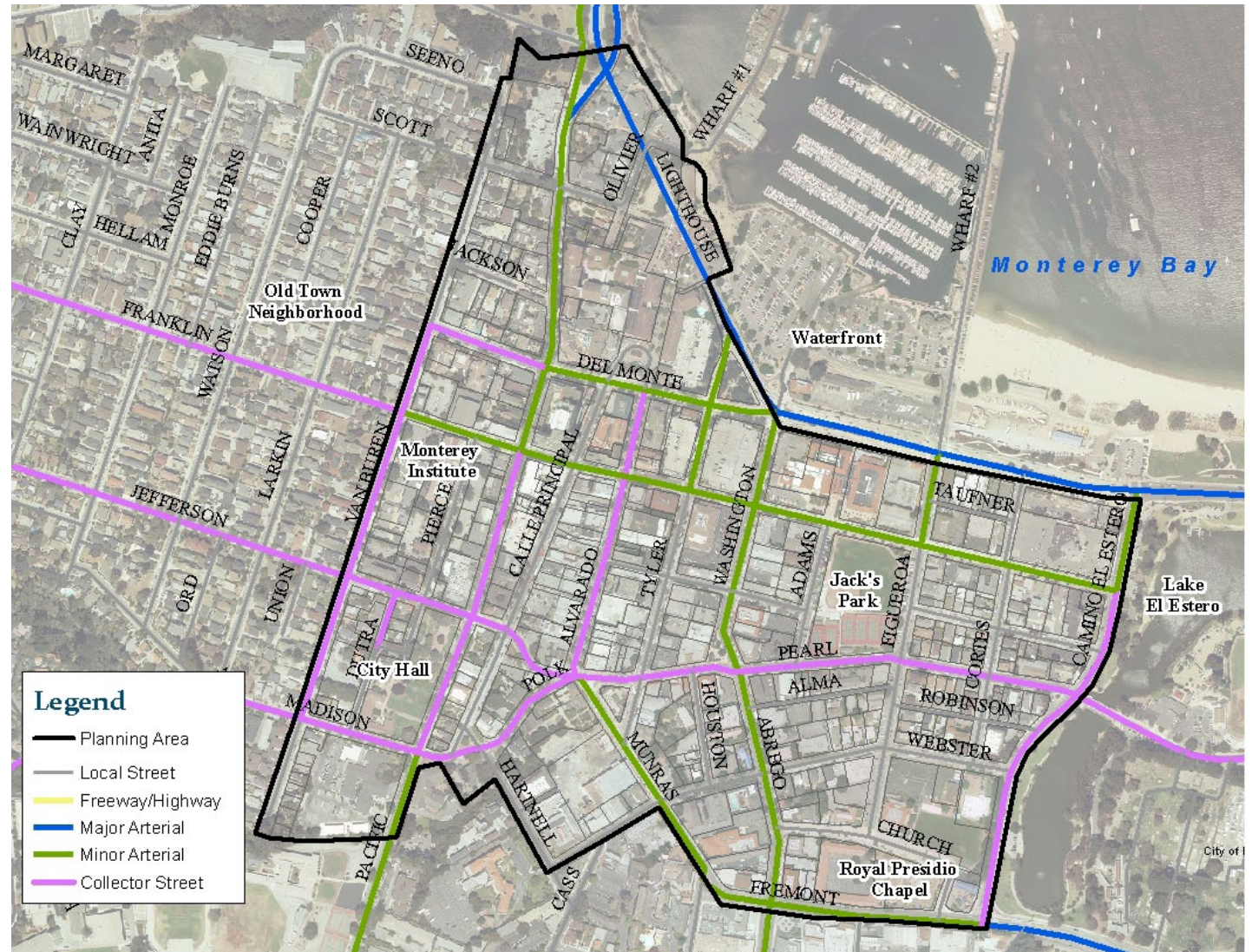

Figure 6: Downtown Street Network

# challenges & opportunities

During the community outreach process, the following circulation-related challenges and opportunities were identified:



## Streets

One way streets make access into downtown difficult and confusing.





# challenges & opportunities

## Transit Service

- Existing transit plaza is an eyesore
- Move transit plaza and create an intermodal center
- Link Wharf I to Downtown via transit/trolley service
- Create a transportation route between downtown and military base
- Horse and buggy rides
- More small shuttles
- Consider light rail or bus rapid transit



## Bicycles

- Need more bike lanes
- Create a bike connection between the Recreation Trail and Downtown
- Improve bike access across Del Monte Avenue
- Need improved bike amenities (lockers, etc.)



# challenges & opportunities

## Pedestrian Experience

- Need more pedestrian-friendly streets
- Need a better defined walking path from Alvarado and Wharf to Waterfront



# challenges & opportunities



## Wayfinding

- Confusing
- Need better signs for locals and visitors
- Need direction to parking facilities
- Need gateways



# challenges & opportunities

## PARKING

Downtown Monterey has a sufficient total parking supply; however, the supply/demand could be optimized. The City's parking garages are underutilized. Conversely, the City's on-street parking supply is relatively full.

In 2012, the City completed a Citywide Transportation and Parking Study to serve as a resource document for the land use plans prepared for North Fremont Street, Downtown, Lighthouse Avenue/Foam Street, and the Waterfront. The Citywide Transportation and Parking Study evaluated existing and future parking needs based on maximizing access to a variety of transportation modes.

As reported in the study, occupancy counts show that at the busiest period (Thursday at noon), only 55% of the parking supply within the Planning Area was occupied, with on- and off-street spaces showing somewhat different occupancy rates (69% and 51%, respectively). At this peak hour, 527 on-street and 2,805 off-street spaces were vacant.

These utilization rates are far below target rates. Target occupancy rates of 85% and 90% are effective industry-standards for analyzing the demand for on- and off-street spaces, respectively. In other words, maintaining 15% and 10% vacancy rates for corresponding on- and off-street stalls help to ensure an "effective parking supply." It is at these standard occupancy levels that roughly one space per block is available, making searching or "cruising" for parking

unnecessary, and allowing off-street lots to maintain adequate maneuverability. Utilization rates much below these targets indicate a diminished economic return on investment in parking facilities.

Turnover is quite high in the downtown area; however, the collected data also revealed that many vehicles were switching spots to avoid the posted time limits. It is likely that employees of downtown businesses are using on-street spaces throughout the day, periodically moving their vehicles to avoid getting a ticket. Approximately 10% of vehicles parking in the downtown area during each count day switched spaces at least once throughout the day.

*Total occupancy counts show that at the busiest period (Thursday at noon), only 55% of the area's parking supply was occupied, with on- and off-street spaces showing somewhat different occupancy rates (69% and 51%, respectively). At this peak hour, 527 on-street and 2,805 off-street spaces were vacant.*

# challenges & opportunities

## General Plan parking policies include the following:

- Require the development of a Citywide Parking Master Plan.
- Effectively manage parking and transportation before investing in costly roadway and parking expansion projects.
- Place parking underground or away from the street to improve the pedestrian experience.
- Minimize the amount of land dedicated to parking needs, especially in commercial business districts and along the scenic coastline.
- Encourage mixed-use development to maximize the shared use of on-site parking.
- Incorporate retail, office or residential community uses into the design of public parking structures.

The Specific Plan encourages the use of the City's parking garages and shared use of existing parking facilities within the Planning Area. These facilities will provide both on-site and off-site, shared parking opportunities for all uses within the Planning Area.

Successful shared parking facilities maximize the use of each parking space by catering to parking demands that occur at opposing times of the day and night. Off-site parking encourages the “park once” mentality, which offers a parking space within a reasonable walking distance to a variety of services. Therefore, the location of these types of parking facilities is key to their successful function.

Should new parking be constructed, the design guidelines encourage structures that take advantage of sloped sites by constructing one or more levels of sub grade parking and therefore minimizing its visual impacts. The design guidelines require other treatments that minimize visual impacts, such as incorporating landscaping within and at the edges of surface lots, and providing a building wrap to a parking structure are appropriate treatments. Locating these facilities away from public view is preferred.

# challenges & opportunities

## PUBLIC UTILITIES

As the framework for delivering basic utility services, the City's infrastructure plays a key role in supporting the commerce and resources found in the Planning Area. Described below are those utilities that the City directly maintains and improves on an on-going basis to ensure the economic viability and sustainability of Downtown study area. Other utilities, such as cable, telephone, and the like, do exist in the Planning Area and are maintained by other entities, both public and private.

### Sanitary Sewer Collection System

The City maintains the sanitary sewer collection system within its jurisdictional boundaries, including that portion in the Planning Area. The existing sanitary sewer collection system conveys sewage from sewer point sources within the City, such as homes, businesses, and public facilities, to the regional wastewater treatment plant for treatment and disposal.

Monterey's sewage, including that sewage load generated in the Planning Area, is conveyed through pipelines to the Monterey Regional Water Pollution Control Agency (MRWPCA) sewer treatment plant for treatment and disposal. Per the MRWPCA, sixty percent (60%) of incoming wastewater is highly treated through their water recycling facility and distributed for irrigation uses on farmlands in northern Monterey County. MRWPCA performs secondary treatment of

the remaining wastewater, which is then discharged through an ocean outfall two miles into Monterey Bay.

Local sewer collection pipelines of various capacities ranging from 6 to 24 inches in diameter exist underground within the Planning Area.

Although the capacity of Monterey's existing sewer collection system is adequate to convey existing sewer loads generated, it is an aged sewer collection system and one that requires on-going maintenance, rehabilitation, and replacement. To date, the City has performed work to document the existing conditions of the system and identify those segments in need of rehabilitation.

Additionally in 2011, the City completed a Sanitary Sewer Utility Fee Study, and concluded that additional funding was necessary to address the backlog of capital repair and replacement needed for this system. As a result, the City held public workshops to inform citizens about these infrastructural needs. The City's current sewer fees are collected from landowners based on flow rates. The MRWPCA rate is based on sewage flow and the cost of treatment. In late 2011, local land owners approved by majority vote a rate increase to fund future sanitary sewer improvements. The City is also pursuing Clean Water State Revolving Fund Program funding to design and construct the necessary system-wide sewer rehabilitation projects.

# challenges & opportunities

## Water

The Planning Area is served by the California-American Water Company (Cal-Am). As of 2010, water availability in the City of Monterey is extremely limited. Water use within the Cal-Am system remains under careful state scrutiny since State Water Resources Control Board Order No. 95-10 was imposed in 1995. State Board Order No. 95-10 requires Cal-Am to reduce the water it pumps from the Carmel River by 20 percent now, and up to 75 percent in the future. Also, any new water that is developed must first completely offset Cal-Am's unlawful diversions from the Carmel River, an estimated 10,730 acre-feet (AF) per year, before any water produced by Cal-Am can be used for new construction or expansions in use.

In October 2009, the State Water Resources Control Board issued a Cease and Desist Order alleging that 1) Cal-Am has failed to comply with Condition 2 of Order 95-10 that requires Cal-Am to terminate its unauthorized diversions from the river, 2) Cal-Am's diversions continue to have adverse effects on the public trust resources of the river and should be reduced, and 3) the ongoing diversion is a violation of Water Code Section 1052 prohibiting the unauthorized diversion or use of water.

The CDO seeks to compel Cal-Am to reduce the unauthorized diversions by specified amounts each year, starting in water year 2008-09 and continuing through water year 2014. The adopted CDO prohibits

Cal-Am from providing new service connections and increasing use at existing service addresses that were not provided a "will serve commitment" (or similar commitment) before October 20, 2009. As of 2012, the CDO action is stayed by a court order.

The Monterey Peninsula Water Management District (MPWMD) has adopted a water allocation system for its service area, including the City of Monterey. No new connections or expanded uses are allowed in a municipal or county jurisdiction that has exceeded its water use allocation. Annual resolutions by the District confirm allotments for each water year. Based on this report, the City of Monterey has either allocated or conditionally reserved effectively all of the water the City can expect to receive from the MPWMD. The City has established a Water Waiting list for those projects that have received all of their required discretionary approvals but do not have adequate water resources to develop this project. As of April 22, 2010, there were 35 projects on the water wait list, accounting for over 35.34 acre feet of water.

The MPWMD has adopted rules that allow the transfer of water between uses and adjacent sites under the same ownership, though these rules are under strict regulation by MPWMD. The City conducted an inventory of water usage and availability, which helped to determine the presence of water credits on a particular site that may be available for an expanded

# challenges & opportunities

use. The identification of water credits assisted in the identification of opportunity sites that could achieve Specific Plan objectives prior to the identification and delivery of a new water source to the City.

## Storm Water Collection System

The City maintains storm drainage infrastructure – drainage channels, storm drains, pipelines, culverts, pump stations, and outfalls - within Monterey, which includes that portion of the storm water collection system located in the Planning Area. The existing system collects non-point surface water runoff and conveys it through channels, pipelines, and culverts that terminate at the Monterey Bay. Monterey’s storm water collection system is not tied into the sanitary sewer collection system. Therefore, storm water flows are, for the most part, not treated prior discharge. All storm water effluent is discharged to local water ways including the Monterey Bay at multiple outfalls located throughout Monterey’s coastal area.

Monterey’s discharge of storm water to the Bay is regulated by the Clean Water Act through the Environmental Protection Agency (EPA) and the State Water Resources Control Board (SWRCB), and permitted through the Central Coast Regional Water Quality Control Board (Regional Board). In 2001, eight local agencies - the cities of Monterey, Carmel-by-the-Sea, Del Rey Oaks, Sand City, Seaside, Marina, Pacific Grove, and the County of Monterey - joined forces to develop their individual NPDES Phase II municipal

permit tasks and to establish a regional storm water management and implementation program. This partnership fostered the development of the Monterey Regional Storm Water Management Program (MRSWMP) and the associated implementation documentation that exists today. In an on-going effort to comply with State and Federal requirements, MRSWMP partner entities meet monthly to discuss their urban runoff issues and develop approaches to properly managing storm water.

Monterey’s existing storm water collection system is an aged one. It is in need of repair and rehabilitation. The City is in the process of documenting the existing conditions of the system and identifying those segments in need of rehabilitation. At present, limited funding is available for this work. Other future storm drain improvements may need to be considered for this Planning Area, such as rerouting flows from streets to gravity storm drains and away from existing storm drain pumping systems for efficiency and better management of flows through and around Downtown.

In 2010, the Regional Board launched the “Joint Effort”, a partnership between the Regional Board and local municipal storm water permittees on the Central Coast. As of January 1, 2011, the Joint Effort required municipalities to regulate LID and hydromodification design standards in private and public development projects. In 2013, the Regional Board Joint Effort team will propose new, long-term storm water design standards for public and private development projects



# challenges & opportunities

to replace existing LID program requirements. Once approved by the Regional Board, the new storm water design standards will be mandated for local implementation through each municipality's Phase II municipal storm water permit. Storm water regulation in general is anticipated to expand in the coming years as a result of new EPA rulings, revised SWRCB permits, and new Regional Board programs that affect local municipal storm water permits.

## **Solid Waste**

The City coordinates, reviews, and implements recycling and waste collection and removal services in Monterey. As such, solid waste is also managed in the Planning Area with scheduled collection and removal services at various frequencies and as demand fluctuates with anticipated levels of service throughout the year.

Solid waste receptacles utilized throughout the study area vary in size and include smaller cans and bins to larger containers, which include dumpsters and compactors. Minimum volumes of solid waste generated by any one use are determined by reviewing several factors of that use, such as the operating details and nature of the use, size of a facility, seating capacity, tenant capacity, number of units, and usage frequency.

Solid waste collection and removal in the Downtown area is performed by an exclusive franchised hauler who maintains service throughout the City, including

commercial and residential entities. Some of the trash enclosures in the Downtown need to be enlarged and reconfigured.

# challenges & opportunities

## CLIMATE ACTION PLAN IMPLEMENTATION

Senate Bill 375 requires that communities coordinate transportation and land use planning for future growth. Specific incentives for projects consistent with this type of coordinated planning effort include exemptions from the California Environmental Quality Act (CEQA) (Source: California Public Resources Code (PRC) Sections 21155.1, 21155.2 and 21159.28).

In 2012, projects may qualify for a CEQA exempt status if they qualify as a Transit Priority Project (TPP), which is defined as follows:

1. At least 50% residential use, based on total building square footage and, if project contains between 26% and 50% non-residential uses, a FAR of not less than 0.75
2. Minimum net density of at least 20 dwelling units per acre
3. Are located within one-half mile of a high quality transit corridor that has fixed route bus service with service intervals no longer than 15 minutes during peak commute hours.
4. The TPP buildings are 15% more energy efficient than Title 24 and the building and landscape designs achieve 25% less water use than the average household in the region.
5. TPP site is not more than eight acres.
6. TPP does not contain more than 200 residential units.
7. TPP does not result in a net loss of affordable housing within the project area.
8. TPP does not include any single level building

exceeding 75,000 square feet.

9. Applicable mitigation measures or performance standards from prior EIRs have been incorporated.
10. TPP does not conflict with nearby industrial uses.
11. The TPP meets one of the following criteria (PRC Section 21155.1 (c)):
  - a. the TPP will sell at least 20% of housing to families of moderate income, 10% of housing will be rented to families of low income, or at least 5% of the housing is rented to families of very low income, and the developer provides legal commitments to ensure the continued availability of these housing units for very low, low-, and moderate income households.
  - b. the TPP developer has paid or will pay in-lieu fees sufficient to result in the development of the affordable units described above.
  - c. the TPP provides public open space equal or greater than 5 acres per 1,000 residents of the project.

The City of Monterey developed a Climate Action Plan that outlines strategies for reducing greenhouse gases to meet the requirements of Assembly Bill 32 and that is consistent with Senate Bill 375. Projects will be required to implement these strategies when possible to meet the City's and State's greenhouse gas reduction goals.

# challenges & opportunities

## FLOOD ZONES

Existing Flood Insurance Rate Maps identify portions of the Planning Area within areas that could be inundated with 100-year and 500-year storm events as indicated in Figure 7 on the facing page. Development in these areas requires mitigation. Additionally, portions of the Planning Area are expected to be within areas projected to be affected by sea level rise. Sea level rise maps have not been developed yet that can be utilized for planning purposes. However, the low elevation areas will most likely continue to be subject to flooding as reflected in the various Flood Insurance Rate Maps and historic flooding maps.

## HISTORIC RESOURCES

Downtown Monterey contains a myriad of historic resources. Figure 8 shows properties that are designated historic resources and those that are eligible or potentially eligible historic resources. The City is periodically updating its historic surveys as recommended by State best practices. The buildings identified in light green may be eligible for historic zoning pending further research.

The City's Historic Preservation Ordinance requires designated and undesignated properties that qualify as historic resources to be reviewed for consistency with the Secretary of Interior Standards for the Treatment of Historic Properties. This Specific Plan continues to embrace this approach.

## SAFETY

During the community workshops, community members expressed concerns about creating and maintaining a safe Downtown. Specific concerns included evening entertainment venues and aggressive panhandling.

## LIGHTING

### Street Light Power Supply

At present (in 2013), approximately half of the streets in the downtown area are served by underground power supply; others are served by overhead power lines. Underground lines exist primarily along the north-south streets of Tyler, Alvarado, Calle Principal and Pacific. A long-term goal is to underground all of the power lines downtown to enhance the aesthetics and reduce maintenance issues downtown.

# challenges & opportunities

## Street Light Styles

A variety of street light styles and light quality exist in the downtown. At the heart, along Alvarado, historic streetlights run its length. They also extend north into the plaza of the Heritage District. The north-south streets that flank Alvarado have either concrete or metal poles, with a variant of a cobra head and arm. Farther east, in the Pearl District, cobra type streetlights are mounted either on wood utility poles or on traffic signals. A distinctly different light style exists along Oliver Street. This is a box-shaped luminaire, mounted on a square metal post. This lack of consistency in light quality and styles fragments the perception of downtown as a whole.

Lighting styles and light quality can play a role in defining downtown character and enhancing wayfinding. This includes lighting the “Path of History” downtown and providing consistent fixtures and light levels.



*Box light on Oliver Street*



*Cobra light in front of historic adobe*

# challenges & opportunities

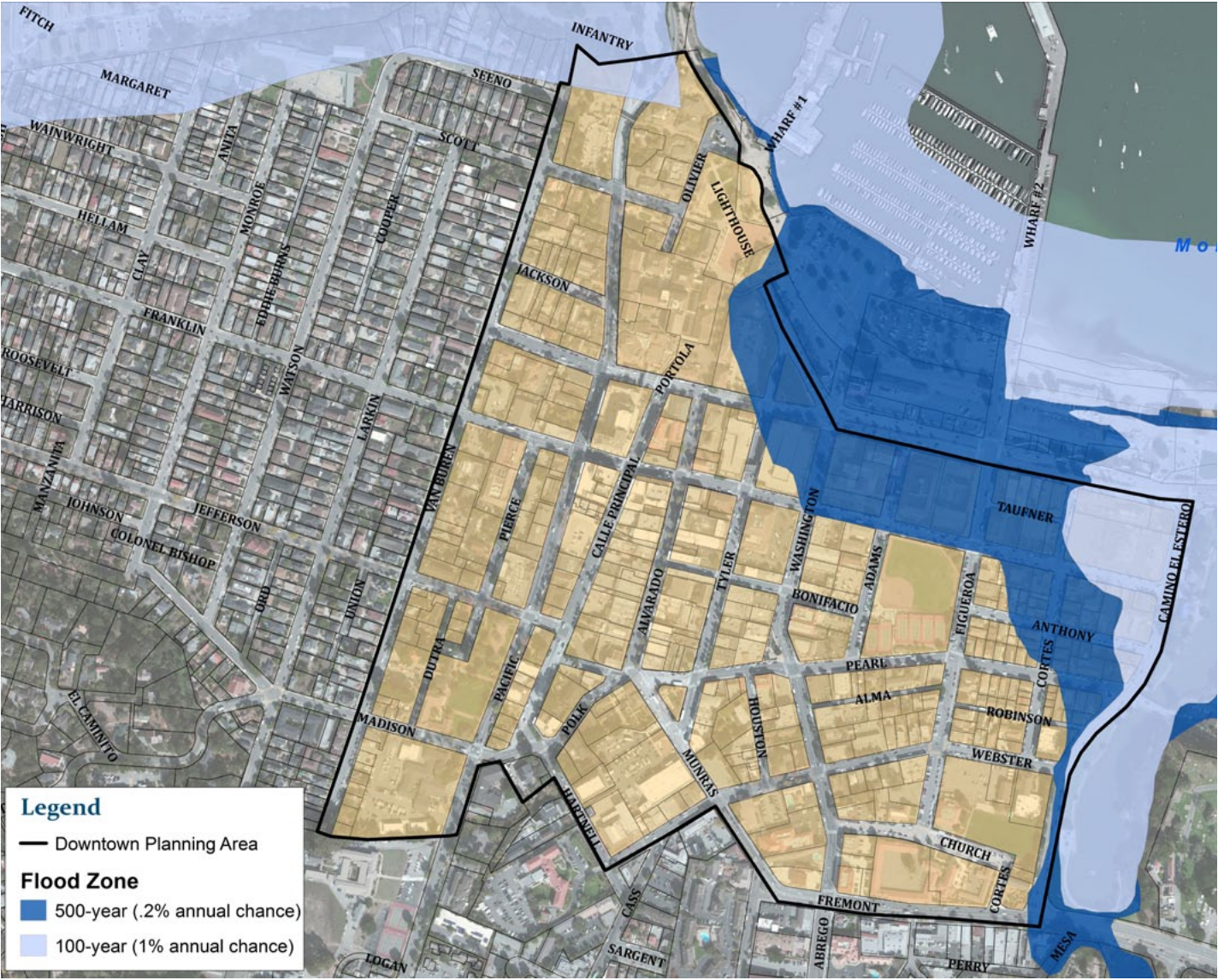

Figure 7: Flood Map

# challenges & opportunities

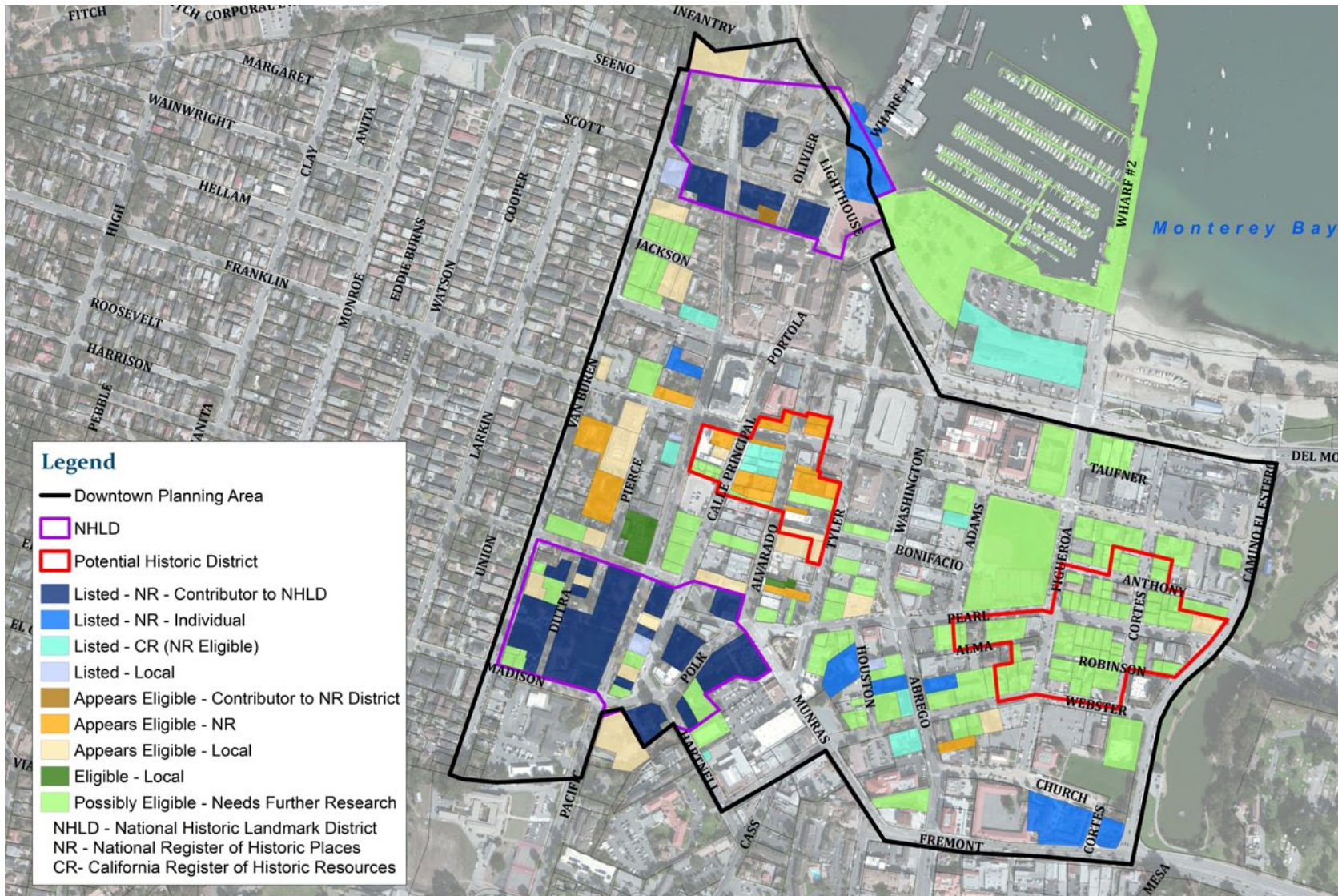

Figure 8: Historic and Potentially Historic Resources

Note: This map is for informational purposes only and is subject to change as individual properties are surveyed.

# 05 land use & development

This page left intentionally blank



# land use & development

## Land Use and Development - Objectives, Standards and Guidelines

The purpose of this section is to provide objectives, standards and guidelines for new land uses and development within the Planning Area. While the Specific Plan goals define the Specific Plan vision at varying levels of specificity, the purpose of the land use and development objectives is to provide a measurement for how a project implements the vision and goals of the Specific Plan. When a project is analyzed for consistency with the Specific Plan, the objectives will serve as findings for approval. A citation of how the project meets a specific guideline or guidelines could serve as support for the findings.

### What's the Difference Between a Standard and a Guideline?

A standard is a requirement for all new development. However, a guideline suggests how a development might achieve a particular design objective. If a project incorporates features that are inconsistent with a particular guideline, the features may be deemed appropriate if adequate support is provided that the features achieve the particular objective.

### 1. Uses

The Vision of the Downtown Specific Plan is to provide a mix of services, special events, and retail establishments of local, regional and national character and development containing a mix of uses including business, retail and residential. All uses in the table on page 67-69 must be found consistent with the objectives, as applicable

#### Applicability:

*The following objectives, standards and guidelines apply to all Character Areas.*

*For development within the Heritage and Island of Adobes Districts (National Historic Landmark Districts (NHLD)), see additional objectives, standards and guidelines located in Chapter 6: NHLD Design Guidelines.*

#### Objectives

- O.1.1. The project includes a commercial component that is one of a wide range of business types including retail, restaurant, hotels, and development containing a mix of uses including business, retail and residential.
- O.1.2. The project is located in the Alvarado District and contains active uses such as retail and restaurants. Mixed-use development is encouraged in this district. Ground floor offices, personal services, and residential on Alvarado Street and the first blocks of Del Monte and Franklin are inappropriate uses (Figure 9)
- O.1.3. The project is located in the East Village or Pearl Districts and provides either active uses or uses that provide services for residents.
- O.1.4. The project is located in the Heritage or Island of Adobe Districts and is complimentary to these nationally significant historic areas.
- O.1.5. The project is located in the Pierce District and provides uses that support and are compatible with office, educational, residential and support commercial.
- O.1.6. The project is located in the Royal Presidio District and contains uses complimentary to sensitive areas, such as educational and residential uses.
- O.1.7. The project is located in the Public Recreation District and contain active or passive recreation uses.

# land use & development



Figure 9: Frontages where offices and personal services are prohibited on first floor

# land use & development

## Uses

P – Permitted

C – Conditionally Permitted

NP - Not Permitted

Use	Alvarado	East Village	Pearl	Heritage	Island of Adobes	Pierce	Royal Presidio	Public Recreation
Amplified Music/ Sound	C	C	C	C	C	C	C	P
Assembly – Minor First floor	Alvarado St. and 1st Block of Del Monte and Franklin –NP  Remaining - P	P	P	P	P	C	C	P
Assembly - Major	C	C	C	C	C	C	C	C
Assembly Minor Above first floor	P	P	P	P	P	P	P	P
Food and Beverage Sales - Major	C	C	C	NP	NP	C	NP	NP
Food and Beverage Sales - Minor	P	P	P	P	P	P	NP	NP
Motor Vehicle Sales and Rental	NP	NP	C	NP	NP	NP	NP	NP
Outdoor Sales	NP	NP	C	NP	NP	NP	NP	NP

# land use & development

P – Permitted      C – Conditionally Permitted      NP – Not Permitted

Use	Alvarado	E a s t Village	Pearl	Heritage	Island of Adobes	Pierce	R o y a l Presidio	P u b l i c Recreation
Park and Recreation Facilities	P	P	P	P	P	P	P	P
Parking Area - Private and Public	Alvarado St. and 1 <sup>st</sup> Block of Del Monte and Franklin -NP Remaining - C	C	C	C	C	C	C	C
Parking - single Family residential	C	P	P	P	P	P	P	P
Parking - Subgrade	C	C	C	C	C	C	NP	C
Residential – Minor and Major first floor	NP	P	P	C	C	C	P	NP
Residential- Minor and Major above first floor	P	P	P	P	P	P	P	NP
Retail Sales - Minor	P	P	P	P	P	C	C	NP
Restaurant - Minor	P	P	P	P	P	C	C	NP
Restaurant - Major	C	C	C	C	C	NP	NP	NP

# land use & development

P – Permitted      C – Conditionally Permitted      NP - Not Permitted

Use	Alvarado	E a s t Village	Pearl	Heritage	Island of Adobes	Pierce	R o y a l Presidio	P u b l i c Recreation
Seating Outside – Incidental and Major	P	P	P	P	P	C	C	P
Service – Minor								
First floor	Alvarado St. and 1 <sup>st</sup> Block of Del Monte and Franklin -NP (except banks) Remaining - P	P	P	P	P	P	P	NP
Above first floor	P	P	P	P	P	P	P	NP
Massage Establishment	U	U	U	U	U	U	U	U
Temporary Uses	Administrative							
Utility Major	C	C	C	C	C	C	C	C
Utility Minor	P	P	P	P	P	P	P	P
Visitor Accommodation Facility	As Allowed in City Municipal Code							

# land use & development

## 2. Site Planning

### GENERAL

O.2.1. Commercial spaces are oriented for the pedestrian.

O.2.2. New development creates a safe pedestrian environment.



### Standards

S.2.1. Maximum residential density

Alvarado District – 100 du/acre

Density Cap Overlay – 30 du/acre for entire area and no limit for individual parcels.

Other Districts – 30 du/acre

S.2.2. Projects on through lots and corner lots shall provide a building face to both streets.

### Guidelines

G.2.1. Within the Alvarado District locate buildings at the back of sidewalk. Locating a small space for outdoor seating use or a recessed entry at the sidewalk edge is appropriate. Locating an entire building front behind the established storefront line is discouraged.

G.2.2. Along Del Monte Avenue, locate buildings at back of sidewalk.

G.2.3. Within the remaining districts, provide a front setback that is within the range of neighboring properties. On some streets, there is no setback (such as Abrego). Other streets have greater setbacks including Webster Street near Figueroa.

G.2.4. Multifamily entrances may be set back from the back of sidewalk.

G.2.5. Outdoor seating may encroach into the public right of way upon grant of an encroachment permit.

G.2.6. If the project provides a pedestrian place of refuge and is designed as a pedestrian-friendly area, the project can depart from the established setback pattern.

G.2.7. Incorporate the following Crime Prevention Through Environmental Design (CPTED) guidelines when feasible:

### Applicability:

*The following objectives, standards and guidelines apply to all Character Areas.*

*For development within the Heritage and Island of Adobes Districts (National Historic Landmark Districts (NHLD)), see additional objectives, standards and guidelines located in Chapter 6: NHLD Design Guidelines.*

# land use & development

## G.2.7.1. Natural Surveillance:

- Place windows overlooking sidewalks and parking lots.
- Create landscape designs that allow surveillance, especially in proximity to points of entry.
- Avoid poorly placed lights that create blind-spots for potential observers and miss critical areas. Ensure potential problem areas are well lit: pathways, stairs, entrances/exits, parking areas, ATMs, phone kiosks, mailboxes, bus stops, children's play areas, recreation areas, pools, laundry rooms, storage areas, dumpster and recycling areas, etc.
- Avoid too-bright security lighting that creates blinding glare and/or deep shadows.
- Use shielded or cut-off luminaries to control glare.
- Place lighting along pathways and other pedestrian-use areas at proper heights.

## G.2.7.2. Natural Territorial Reinforcement

- Maintain premises and landscaping such that it communicates an alert and active presence occupying the space.
- Provide trees. Outdoor residential spaces with more trees are seen as significantly more attractive, more safe, and more likely to be used than similar spaces without trees.

### *Natural Surveillance*

*Natural surveillance occurs by designing the placement of physical features, activities and people in such a way as to maximize visibility and foster positive social interaction among legitimate users of private and public space. Potential offenders feel increased scrutiny and limitations on their escape routes. Natural surveillance measures can be complemented by mechanical and organizational measures. For example, closed-circuit television (CCTV) cameras can be added in areas where window surveillance is unavailable.*

- Display security system signs at access points.
- Place amenities such as seating or refreshments in common areas in a commercial or institutional setting helps to attract larger numbers of desired users.

# land use & development

## TOPOGRAPHY

### Objectives

O.2.3. No portion of the project shall appear out of scale as compared to the street due to topographical changes on the site.

### Guidelines

- G.2.8. Take advantage of a sloped site by creating a basement or parking when feasible.
- G.2.9. Minimize grading unless underground parking is provided.

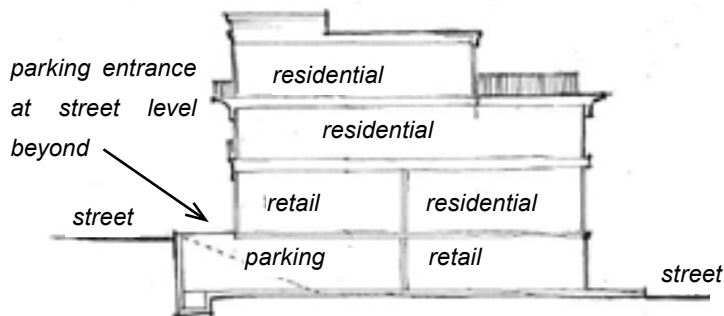

## OPEN SPACE

### Objectives

O.2.4. The project provides sufficient open space to enhance livability by providing a pleasant outdoor environment.

### Guidelines

- G.2.10. Provide open space areas that enhance the site as a place for pedestrians.
- G.2.11. Provide open space that is a focal point for the site.
- G.2.12. Design open space areas to provide views of public activity areas, such as sidewalks, streets and plazas.
- G.2.13. Design open space to provide safe, convenient access to the various uses within a site.
- G.2.14. Design open space to connect to primary pedestrian circulation routes and contribute to a network of streets, paseos, and alleys that provide access to secondary uses.
- G.2.15. Cluster buildings to create active outdoor public space.
- G.2.16. Usable open space may be composed of one or more of the following elements:
  - A courtyard



# land use & development

- A patio
- A landscaped front yard (Pearl and Pierce Districts only)
- Rooftop deck
- Balconies
- Public sidewalk or plaza (Alvarado District only)

G.2.17. Provide outdoor spaces for residents such as rooftop decks, patios, balconies, etc.

G.2.18. Encourage new development to incorporate public artwork and landscaping elements.

G.2.19. Use open space to connect the entrances of two buildings on a site.

G.2.20. Enhance pedestrian and bicycle connections wherever feasible.

G.2.21. Provide direct pedestrian access from a public sidewalk to the majority of individual uses and spaces on a property. Appropriate pedestrian connections include the following:

- Sidewalks
- Internal walkways
- Courtyards and plazas
- Paseos through blocks

G.2.22. Provide pedestrian access that is adequate in size, availability, accessibility and function to satisfy demands relative to the size of the project and proposed use(s).



G.2.23. Locate a walkway so that key destination points, such as building entries, are clearly visible.

G.2.24. Site a path in an area that will remain visible from active public spaces.

G.2.25. Define walkways with landscaping, site furniture and pedestrian-scaled lighting.

# land use & development

## PUBLIC UTILITIES AND BUILDING SERVICES

### Objectives

O.2.5. Trash, service areas, and equipment areas are located to decrease impacts on the streetscape appearance and function.

### Standard

S.2.3. Fire sprinkler risers, back flow preventers, trash areas, and other utilities shall be located inside a building or completely screened from public view.

### Guidelines

G.2.26. Store trash and recycling within an enclosed area in accordance with the City's Waste Enclosure Guidelines.

G.2.27. Design service areas to be on site and away from public sidewalks when feasible.

G.2.28. Screen equipment from view. Screening devices may include building parapets, landscape elements, and architectural features.

G.2.29. Paint rooftop equipment to match the roof.

G.2.30. Use mechanical units on rooftops that are not visible from public ways.



G.2.31. Locate utility meters out of public view when feasible.

G.2.32. Provide appropriate setbacks to telephone poles, traffic lights, utility boxes, etc.

# land use & development

## PARKING

### Objective

O.2.6. Parking facilities are conveniently located and designed to be attractive, compatible additions that provide a pedestrian-friendly edge to the area.

### Standards

- S.2.4. Parking garages shall have active ground floor uses or pedestrian-friendly edge (public art, landscaping, etc.)
- S.2.5. Parking lots shall be screened from the public right-of-way
- S.2.6. Parking requirements:
- S.2.6.1. Commercial: Maximum of four spaces per 1,000 GSF. No minimum requirement for commercial.
  - S.2.6.2. Residential: .5 spaces per unit. Maximum of 2 spaces per unit. All new residential development shall “unbundle” the full cost of parking from the cost of the housing itself, by creating a separate parking charge.
  - S.2.6.3. Parking space requirements may be met with an in-lieu fee.
  - S.2.6.4. Parking may be shared between:
    - different uses within a single mixed-use building.



- residential buildings and an off-site parking facility, provided that the off-site facility is within 1,000 feet of the building entrance.
  - non-residential buildings and an off-site parking facility, provided that the off-site facility is within 1,250 feet of the building entrance.
- S.2.6.5. Off-site shared parking located further than 1,000 feet can be considered at the discretion of staff, so long as there is documentation that reasonable provision has been made to allow off-site parkers to access the principal use (e.g. a shuttle bus, valet parking service, free transit passes, etc.)

# land use & development

## Guidelines

- G.2.33. Locate parking in an offsite structure or area. (Alvarado, Heritage, Island of Adobes District)
- G.2.34. Locate parking in an offsite structure or area to the side or rear of the structure. (East Village, Pearl, Pierce, Royal Presidio and Public Recreation Districts)
- G.2.35. Access parking from alleyways when feasible. (East Village and Pearl Districts)
- G.2.36. Share driveways when feasible to reduce the number of curb cuts. (East Village and Pearl Districts)
- G.2.37. Locate curb cuts away from intersections to minimize conflicts with pedestrian and traffic movement.
- G.2.38. Develop the street elevation of a parking structure with a retail/commercial building wrap.
- G.2.39. Incorporate one or more of the following into the secondary elevations of a parking structure:
- Retail/commercial wrap
  - Murals or public art
  - Decorative architectural features
  - Display cases
  - Landscaping
  - Public amenities (street furnishings)
- G.2.40. Design structures or surface lots to minimize light and noise impacts to adjacent properties.
- G.2.41. Use Crime Prevention Through Environmental Design (CPTED) standards to maximize safety and crime prevention.
- G.2.42. Locate a surface lot behind a building whenever feasible.
- G.2.43. Site a parking lot so it will minimize gaps in the continuous building wall of a block.
- G.2.44. Landscape surface parking lots along the street frontage.

# land use & development

## 3. Building Design, Mass and Scale

### Objectives

- O.3.1. The building design conveys a sense of local identity and reflects the evolving character of the area.
- O.3.2. The building design complements the natural features of Monterey.
- O.3.3. The building design respects the traditional character of the area while reflecting its own period and function.
- O.3.4. Buildings that occur at a major intersection provide an anchor at the corner.
- O.3.5. The project contributes to a variety of height and mass along the streetface.

- O.3.6. The rhythm and scale of the street wall is designed to enhance the pedestrian experience.
- O.3.7. The building design includes façade components that help establish traditional building composition.
- O.3.8. The project is consistent with the Secretary of the Interior's Standards for the Treatment of Historic Properties if it has the potential to impact a historic resource.
- O.3.9. The project qualifies as a Transit Priority Project (TPP) and implements the City's Climate Action Plan.



# land use & development

## Standards

### S.3.1. Maximum Stories\*:

- Alvarado District - 4 stories
- Density Cap Overlay - 4 stories for projects with at least 50% of FAR dedicated to residential use.
- East Village District - 3 stories
- Pearl District - 3 stories
- All other districts - 2 stories

T.Note: Visitor Accommodation Facility zoned properties shall be subject to development standards set forth in City Code Chapter 38 and City Charter Section 8.1.

\* See definition of a “story” in Chapter 11

S.3.2. To qualify as a Transit Priority Project (TPP), the project must comply with the definition contained in the California Environmental Quality Act.

## Guidelines

- G.3.1. Use simple rectangular forms with flat, gable or hip roofs. Other forms may be used as an accent and should remain subordinate. These elements will be reviewed on a case-by-case basis.
- G.3.2. Encourage new interpretations of traditional building styles.
- G.3.3. Define prominent building corners with a strong building presence.

### *Transit Priority Project*

*A **Transit Priority Project (TPP)**, is defined by the California Environmental Quality Act (CEQA) Section 21155, and is a project that generally meet the following criteria:*

*(1) contains at least 50 percent residential use, based on total building square footage and, if the project contains between 26 percent and 50 percent nonresidential uses, a floor area ratio of not less than 0.75;*

*(2) provides a minimum net density of at least 20 dwelling units per acre; and*

*(3) is within one-half mile of a major transit stop or high-quality transit corridor included in a regional transportation plan.*

*Refer to CEQA Section 21155 for additional requirements and exceptions.*

# land use & development

- G.3.4. Enhance block corners with a pedestrian-friendly entrance plaza. This may include human-scaled design features such as benches and planters.
- G.3.5. Enhance the pedestrian experience by incorporating:
- A base, middle and cap into the building design.
  - Variation in height at internal lot lines
  - Variation in the plane of the front façade
  - Variation in architectural detailing and materials to emphasize the building module.
- G.3.6. Vary building, façade, and/or parapet heights to reflect traditional lot width, possibly in conjunction with setting back an upper floor, across the width and the depth of the building, or at the front.
- G.3.7. Repeat wall elements, including windows, columns, ornamental trim and architectural features, such that rhythms and patterns result.
- G.3.8. Use horizontal elements such as porches, balconies and horizontal coursing to break up the vertical mass of a wall.
- G.3.9. Maintain the alignment of horizontal building elements along the street.
- G.3.10. Refer to the illustrative sketches for specific design guidelines for each district.
- G.3.11. Orient building entrances toward the street.
- G.3.12. In the Pearl District, provide one-story porch elements at street entrance compatible with neighboring properties (except facing Del Monte Avenue).
- G.3.13. Encourage maximum transparency at street level in the Alvarado District.
- G.3.14. Design buildings facing Van Buren Street to be more residential in character and scale.



# land use & development

## ILLUSTRATIVE DESIGN EXAMPLES

### Alvarado District

*This section provides illustrative examples of how the design guidelines outlined above can be implemented in a project. Each guideline is numbered and refers to a specific design feature in the illustration.*

*G.3.1. Use simple rectangular forms with flat, gable or hip roof*

*G.3.5. Incorporate a base, middle and cap into the design*

*G.3.11. Orient building entrances toward the street*

*G.3.6. Vary building facade widths and/or parapet heights*

*G.2.14. Design open space to connect to primary pedestrian circulation routes*



*G.3.13. Encourage maximum transparency at street level*

*G.3.8. Use horizontal elements such as porches, balconies and horizontal coursing to break up the vertical mass of a wall*



# land use & development

## East Village District

G.3.1. Use simple rectangular forms with flat, gable or hip roof

G.2.34. Locate parking area to the side or rear of the structure

G.3.2. Encourage new interpretations of traditional building styles

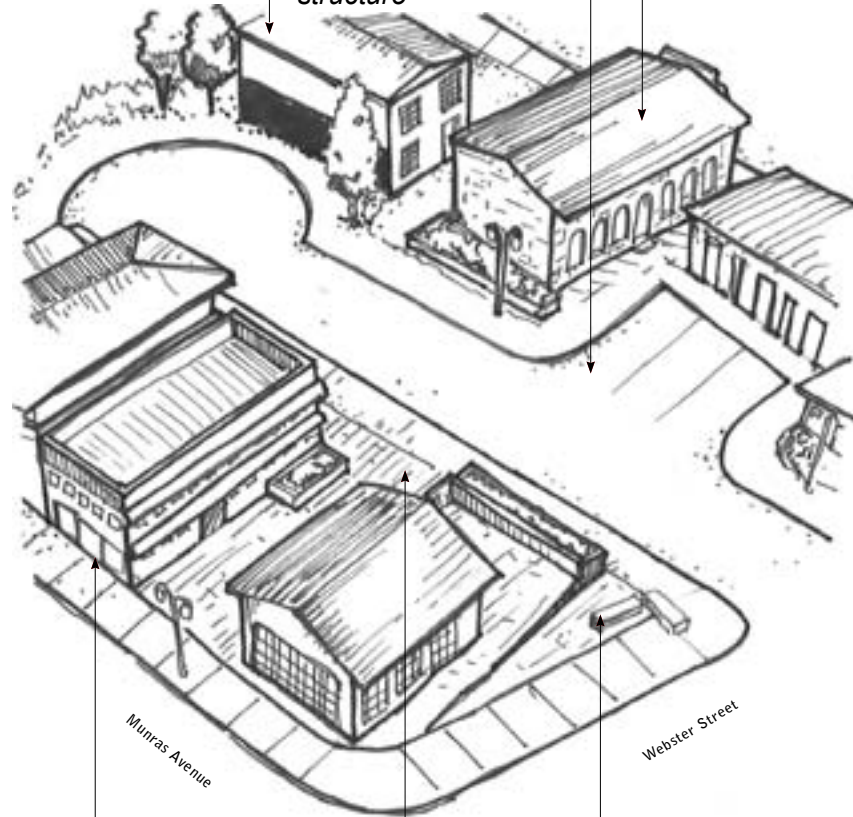

G.3.11. Orient building entrances toward the street

G.2.15. Cluster buildings to create active outdoor public space

G.3.4. Enhance block corners with a pedestrian-friendly entrance plaza

# land use & development

## Pearl District (Del Monte Avenue)

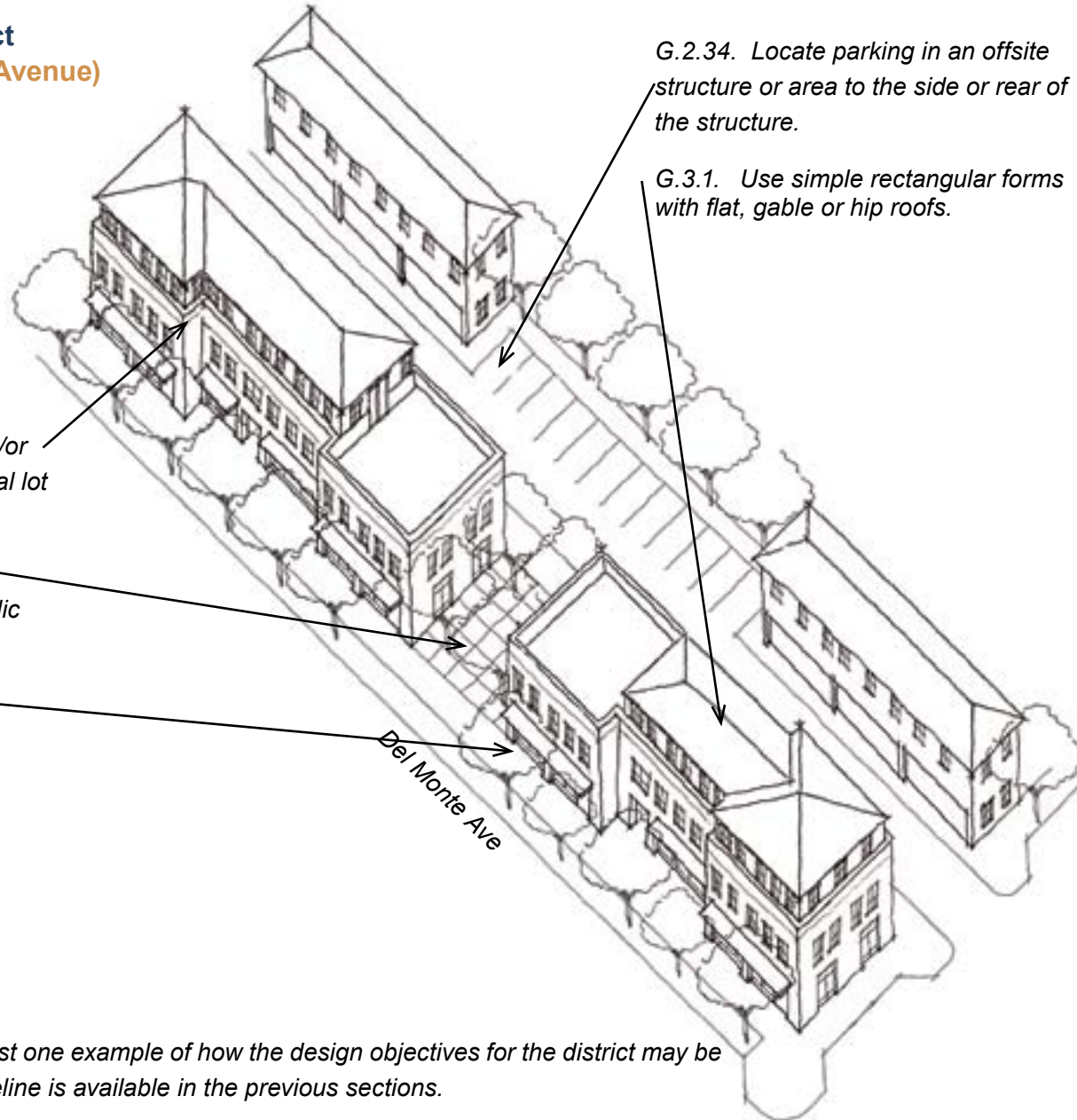

G.3.6 Vary building, façade, and/or parapet heights to reflect traditional lot width.

G.2.24. Site a path in an area that will remain visible from active public spaces.

G.3.11. Orient building entrances toward the street

G.2.34. Locate parking in an offsite structure or area to the side or rear of the structure.

G.3.1. Use simple rectangular forms with flat, gable or hip roofs.

Note: The illustration above is just one example of how the design objectives for the district may be achieved. Full text of each guideline is available in the previous sections.

# land use & development

## Pearl District

G.3.6. Vary building facade widths and/or parapet heights

G.3.1. Use simple rectangular forms with flat, gable or hip roof

G.2.24. Site a path in an area that will remain visible from active public spaces

*Note: This illustration is just one example of how the design objectives for the district may be achieved. Full text of each guideline is available in the previous sections.*

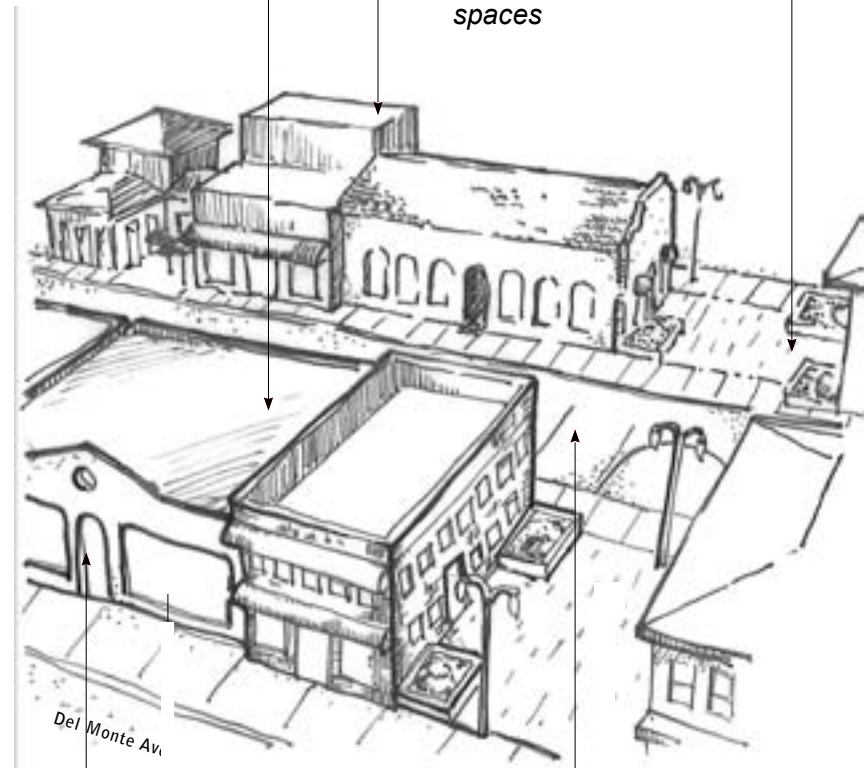

G.2.34. Locate parking in an offsite structure or area to the side or rear of the structure

G.3.11. Orient building entrances toward the street

# land use & development

## Pierce District

*G.3.12. Orient building entrances toward the street*

*G.3.14. Locate storefronts at street level along Pacific Street.*

*G.3.16 Design buildings facing Van Buren Street to be more residential in character and scale.*

*G.3.1. Use simple rectangular forms with flat, gable or hip roofs.*

*G.3.7. Provide a well balanced solid-to-void ratio that holds the interest of the pedestrian.*



*Note: The illustration above is just one example of how the design objectives for the district may be achieved. Full text of each guideline is available in the previous sections.*

# land use & development

## 4. Colors

Monterey has a diverse architectural heritage. Building colors should appropriately reflect the building architecture and compliment the setting of the districts.

### Standards

- S.4.1. Use a creative mix of colors to reflect architectural style
- S.4.2. Brick and stone shall not be painted but previously painted surfaces may be repainted.

### Objectives

- O.4.1. The building color reflects the architectural style of the building
- O.4.2. The building colors compliment the district and adjacent buildings



*Appropriate: Colors that reflect architectural style*



*Appropriate: Natural materials (brick) and compatible colors*



*Appropriate: Colors that reflect Victorian style (defined colors and highlight details)*

# land use & development



*Inappropriate: Colors incompatible with district (lime green base, blue sign, turquoise details)*



*Appropriate: Colors that reflect Spanish Revival style (neutral base with defined elements)*



*Appropriate: Unpainted concrete when part of style*



*Appropriate: Colors compatible with Monterey Colonial style*



*Appropriate: Colors that reflect historic building styles*  
**downtown specific plan**



*Appropriate: Creative use of color*

# land use & development

## 5. Building Materials

### Objective

- O.5.1. Building materials convey a sense of “belonging” in the setting of the District.
- O.5.2. Building materials are durable and low maintenance to avoid maintenance issues.

### Guidelines

- G.5.1. Use traditional building materials with appropriate detailing that reduce the perceived scale of a building.
- G.5.2. Use materials that convey a hand-crafted character.
- G.5.3. Use durable materials that have proven performance in the Monterey climate.
- G.5.4. Use high quality materials.



*Durable materials with a hand-crafted appearance*



*Durable materials with a hand-crafted appearance*

- G.5.5. Large panelized products and extensive featureless surfaces are inappropriate.
- G.5.6. Changes in color, texture and materials can also help to define human scale and should be incorporated in building designs.
- G.5.7. Awning shape, color, material, and location on the building should be compatible with the building architecture, relate well to the dominant architectural features, and not hide important details or defining building materials.
- G.5.8. Awnings should not impose a new or incompatible shape or style on a building.

# land use & development

## 6. Lighting

Lighting is an integral component of successful design and has a significant impact on the feeling and character of an area. Lighting standards and guidelines apply to property lighting visible from the public way within the planning area. They address the design and placement of poles and fixtures, lighting levels, and lighting quality. Lighting plans shall be prepared and submitted for review as part of the project. Lighting plans must indicate all exterior lighting fixture locations, height, type of light source, fixture type and pole type. A photometric study may be required for parking lots.

### Objectives

- O.6.1. The lighting continues a consistent character and level of lighting that protects the dark sky.
- O.6.2. The lighting is sensitive to residential uses.
- O.6.3. The project's use of lighting is limited to providing an accent for building entrances; lighting signs; and providing a safe and secure environment for public places.
- O.6.4. The lighting source is efficient.
- O.6.5. The project's lighting is appropriate for the site.
- O.6.6. The project's light does not result in glare and does not spill beyond its subject.
- O.6.7. Lighting establishes a distinct

identity for downtown at night and during the day.

- O.6.8. Lighting is compatible with historic resources as well as other traditional buildings types, materials and finishes.
- O.6.9. Lighting complements retail display and nighttime activity.
- O.6.10. Lighting within the downtown area is appropriate for the area's historic resources, design character and safety needs.
- O.6.11. Crime Prevention Through Environmental Design (CPTED) Standards have been incorporated where feasible.



*Lighting compliments retail display*



# land use & development

## Standards

- S.6.1. Exposed bulbs are prohibited except filament bulbs.
- S.6.2. All lamps shall be directed downward unless highlighting architectural features. Lamp shall not be visible from side or from behind fixture when lighting architectural details.
- S.6.3. Outlining roof elements and building with lighting is prohibited.
- S.6.4. Lighting shall be in the range of 2700 to 3500 kelvin temperature except as specified below:
  - Architectural Details - 2700K to 4100K. Warmer color temperatures are to be used for lighting larger architectural features while cooler colors are to be limited to small architectural features.
- S.6.5. Lamps shall be fully shielded or directed away from residential areas, neighboring properties and the public right-of way.
- S.6.6. Lighting near mixed-use buildings shall not have direct impact on upper story residential windows.
- S.6.7. Lighting shall provide sufficient light for safety, but shall not generate excessive glare.
- S.6.8. Interior lighting shall be taken into consideration and included in lighting measurements to achieve appropriate lighting levels and color range.
- S.6.9. Maximum pole height: 15 feet



*Not permitted: Outlining roof elements and building with lighting*

## EXAMPLES OF SOME COMMON LIGHTING FIXTURES

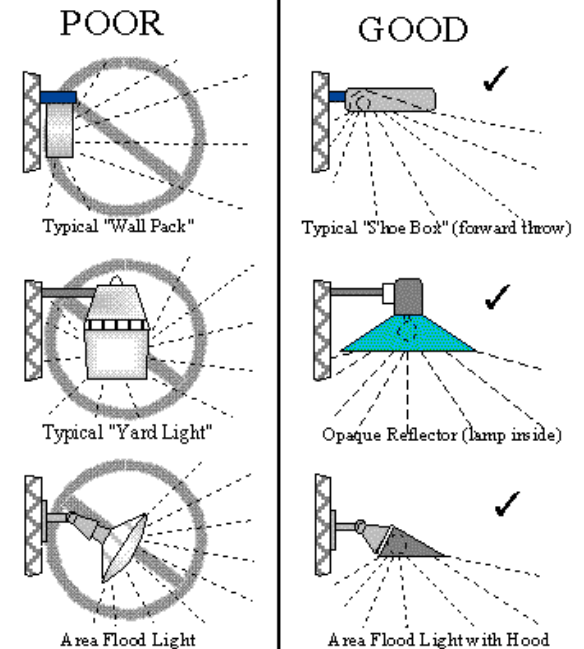

# land use & development

S.6.10. Projects shall design to and maintain the following maximum light levels and spacing:

- Plazas, Paseos, and Alleys - Spacing to meet average maintained illumination levels up to a maximum 1.0 footcandles.
- Courtyards - Light level: 5 footcandles maximum
- Buildings - Spacing to meet average maintained illumination levels of a minimum 0.5 footcandles and maximum 1.0 footcandles.
- Primary Building Entry - Not to exceed average maintained illumination levels of a maximum 5.0 footcandles
- Architectural Details - Light level: 2-5 footcandles average.
- ATMs - Not to exceed California Financial Code footcandle requirements
- Canopies - Average 10 footcandles maximum
- Parking Lots - Spacing to meet average maintained illumination levels of a maximum of 0.5 footcandles and a 15:1 maximum to minimum uniformity ratio.
- Service Areas - 10 footcandles maximum

## Guidelines

- G.6.1. Shield lamps to prevent glare unless a filament bulb is used.
- G.6.2. Use energy efficient lamps.



*Encouraged: Shade devices are consistent with building design*

- G.6.3. Avoid “uplighting” of entire building faces or outlining the frame or roof of a building.
- G.6.4. Use simple shade devices consistent with the building design to shield lamps.
- G.6.5. Provide a relatively warm light color that complements product displays and supports nighttime outdoor events.
- G.6.6. Minimize glare from lamps and instead focus light at intended surfaces.
- G.6.7. Exterior lighting should accomplish a generally subdued and uniform lighting pattern with a minimum potential for glare with combinations of multiple indirect lamps as opposed to fewer, more powerful direct lamps.
- G.6.8. All exterior lighting (public and private) should be compatible with the historic character of the area.

# land use & development



*Discouraged: Building wall lighting too bright and not well shielded.*



*Encouraged: Soft lighting of historic adobe buildings with hidden fixtures.*

- G.6.9. Uplighting should be limited to landscape lighting and to highlight historic landmark adobe buildings.
- G.6.10. Lighting in trees in private yards should be at a low level, to remain subordinate to the overall street lighting.
- G.6.11. The use of low intensity, concealed lights that softly illuminate the historic landmark adobe facades is appropriate. This would help to identify these resources at nighttime and therefore supplement heritage walks.
- G.6.12. Downtown Paseos have the historic street light design. Where space is available, these should be on poles; in other locations, they may be bracket mounted on walls.
- G.6.13. Wall mounted lights - Historic styles are encouraged, especially within the core area.
- G.6.14. In general, building walls should not be illuminated (except where the wall surface is part of a sign). An exception is for historic landmarks, with these provisions:
  - Lighting should be indirect, from concealed sources
  - Lighting should not shine up into the sky.
  - A relatively low level of lighting should be used.
- G.6.15. Canopies - Lighting should be recessed and concealed.
- G.6.16. With the exception of building lighting, fixtures should be motion sensing with light reduced to ½ of maximum.

# land use & development

## 7. Signs

These sign standards and guidelines are in addition to the standards set forth in Chapter 31 of the Monterey City Code and the Citywide Sign Guidelines, which regulate signs citywide. If any conflict in standard or guidelines is perceived, the standards and guidelines contained in the Specific Plan shall take precedence.

Monterey Municipal Code Chapter 31, Signs, also provides the standards for review and the process for sign applications. In addition, the City of Monterey has adopted Citywide Sign Guidelines. The following guidelines shall preempt any of the Citywide Sign Guidelines for all properties within the plan boundaries of the Specific Plan.



### Objectives

- O.7.1. The sign design and scale is integrated into the design fabric of Downtown Monterey.
- O.7.2. The visual prominence of the sign is appropriate to allow for the views of buildings, trees, and streetscape.
- O.7.3. The design of the sign continues the unique design character of Downtown Monterey and its Character Areas.

### Standard (all Districts)

- S.7.1. Internally illuminated signs are prohibited.

### Design Guidelines

#### The Alvarado District and the East Village District

- G.7.1. Projecting signs and wall signs are preferred.
- G.7.2. Awning signs, though acceptable, should be used with restraint and should only be located above an entry.
- G.7.3. Freestanding signs are entirely inappropriate due to the pedestrian nature of the area and the desire for back-of-sidewalk development.
- G.7.4. A-Frame Signs are encouraged throughout, when located on private

# land use & development

property, and subject to the restrictions contained in the Citywide Sign Guidelines.

## The Pearl District

- G.7.5. Pedestrian-oriented freestanding signs are encouraged for those sites containing a converted residential building with a front yard of at least six (6') feet in depth.
- G.7.6. Installed signs on converted residential buildings should not conflict with existing architectural features.



## The Public Recreation District

- G.7.7. Orient signs towards the vehicle or pedestrian entry to the facility.



## The Heritage District, Pierce District, and Royal Presidio District

- G.7.8. Minimize signs.
- G.7.9. Use historically-appropriate materials. Hand-painted or hand-carved signs are preferred.
- G.7.10. Avoid installations on adobe buildings if such installation will require drilling or other hard-mounting to the building. Painted or applied signs are appropriate.
- G.7.11. Consider installation of historic signs to interpret a resource.



# land use & development

## 8. Landscaping

### Objectives

- O.8.1. The project complies with the City's Water Efficient Landscape Ordinance as specified in the City's Municipal Code.
- O.8.2. The landscaping is simple, drought tolerant and easy to maintain.
- O.8.3. The landscaping uses a few plant species, as opposed to detailed planting with multiple plant types.
- O.8.4. The sidewalk trees selected will arch over the roadway as they mature (at suitable clearances for trucks and buses).
- O.8.5. The project includes street trees that will not drop leaves or seeds that may become a hazard for pedestrians or cyclists and include an adequate tree grate system that will contain the roots to avoid impacting the pedestrian and bicycle infrastructure.

### Standard

- S.8.1. Projects are required to plant street trees at appropriate intervals.
- S.8.2. Fruiting trees along public walkways are prohibited.

### Design Guidelines

- G.8.1. Use a predominance of native and drought tolerant trees and plants.
- G.8.2. Use street tree grates that have the ability to contain root systems so that the sidewalk is not disturbed.
- G.8.3. Fruit trees can be used in landscape designs if pedestrian areas are avoided.



# land use & development

## Plant List

The following is a preferred plant list that contains the most commonly used plants in Monterey's City Parks, public grounds, medians and traffic islands with a focus on native and drought tolerant species.

## Trees

To implement the Specific Plan, the City will develop a comprehensive street tree plan for the Planning Area. The following tree species are recommended for consideration in the plan.

### Alvarado Street

The existing Alvarado Street trees should be replaced with a more compact, flowering tree with a smaller leaf. The following trees are recommended for consideration:



*Gleditsia triacanthos inermis*  
**Honeylocust**



*Prunus x yedoensis*  
**Akebono Cherry**



*Albizia julibrissin*  
**Silk Tree**



*Crataegus phaenopyrum*  
**Washington Hawthorne**



*Crataegus viridis*  
**'Winter King' Hawthorne**

# land use & development

## Street Trees

The following street trees should be considered in the future street tree plan in addition to the previous tree recommendations for Alvarado Street.



*Pistacia chinensis*  
**Chinese Pistache**



*Lagerstroemia*  
**Crape Myrtle**



*Liriodendron tulipifera L.*  
**Tulip Tree**



*Magnolia x soulangeana*  
**Saucer Magnolia**



*Magnolia grandiflora*  
**'Little Gem' Southern Magnolia**



*Quercus rubra*  
**Red Oak**



*Quercus palustris*  
**Pin Oak**



*robinia idahoensis*  
**Chanticleer Pear**

Source:<http://plants.usda.gov>



# land use & development

## Tall Shrubs and Perennials



*alyogyne heugilli*  
**Blue Hibiscus**



*ceanothus Julia Phelps*  
**Ceanothus**



*echium candicans*  
**Pride of Madiera**



*euryops pectinatus*  
**Euryops**



*romneya coulterii*  
**Matilija Poppy**



*impatiens olivari*  
**Evergreen Impatien**



*lavatera maritima bi color*  
**Tree Mallow**



*phlomis fruticosa*  
**Jerusalem Sage**



*phormium tenax*  
**New Zealand Flax**



*viburnum tinus S.B.*  
**Laurustinus**



*podocarpus gracilior*  
**Yew Pine**



*polygala dalmaisiana*  
**Sweet Pea Shrub**



*salvia leucantha*  
**Mexican Sage**



*tagates lemonii*  
**Bush Marigold**



*westringia fruticosa*  
**Australian Rose**

# land use & development

## Short Shrubs and Perennials



*agapanthus orientalis*  
**Lily of the Nile**



*artemesia Powis Castle*  
**Artemesia**



*acanthus mollis*  
**Bears Breech**



*bidens ferulifolia*  
**Bidens**



*coleonema pulchrum*  
**Breath of Heaven**



*correa pulchella*  
**Australian Fuchsia**



*dietes vegeta*  
**Fortnight Lily**



*erigeron karvinskianus*  
**Santa Barbara Daisy**



*gaura lindheimeri*  
**Gaura**



*heuchera maxima*  
**Island Alum Root**



*lobelia laxifolia*  
**Lobelia**



*salvia x bees bliss*  
**Salvia**

# land use & development

## Vines



*bougainvillea*  
**Bougainvillea**



*hardenbergia violacea*  
**Lilac Vine**



*jasminum polyanthum*  
**Pink Jasmine**



*loniceria hildebrandiana*  
**Burmese Honeysuckle**



*solanum jasminoides*  
**Potato Vine**



*thunbergia gregorii*  
**Orange Clock Vine**



*wisteria sinensis*  
**Chinese Wisteria**

## Ground Covers



*ajuga reptans*  
**Carpet Bugle**



*campanula*  
**Bellflower**



*ceanothus Carmel creeper*  
**Ceanothus**



*gazania hybrids*  
**Gazania**

This page left intentionally blank

# 06 National Historic Landmark District design guidelines

This page left intentionally blank

# National Historic Landmark District design guidelines

## About the Design Guidelines

This document establishes design guidelines for the Old Town National Historic Landmark District (NHLD) in downtown Monterey. Allowed uses are as listed in Chapter 5, Uses.

## The Importance of the Old Town National Historic Landmark District

While the main body of the Downtown Specific Plan provides clear guidance for development in the downtown, the special significance of the National Historic Landmark District merits some detail and direction, and thus these guidelines are provided.

## What are the Design Guidelines?

Design guidelines address alterations to existing structures, additions, new construction and site work. They define a range of appropriate responses to a variety of specific design issues.

Some of the guidelines are written specifically to be used when improving historic structures, others apply to non-contributing, existing buildings and still others apply to new infill construction.

## Why Have Design Guidelines?

The design guidelines provide a basis for making consistent decisions about the appropriateness of improvements that are subject to approval in the City's design review process. In addition, they serve as educational and planning tools for property owners and design professionals.

## How Will These Design Guidelines Be Used?

The design guidelines are used primarily by property owners, design professionals, city staff, and the Historic Preservation Commission.

While the guidelines are written for use by the layperson, property owners are strongly encouraged to enlist the assistance of qualified design and planning professionals, including architects and preservation consultants.

## Background of the Design Guidelines

The preservation of historic structures and districts in the City of Monterey is accomplished through its planning documents and municipal code. The 2005 City of Monterey General Plan, which represents the City's official land use policy, includes a Historic Preservation Element with a primary goal of preserving historic and cultural resources in Monterey, including buildings, sites, landscapes, artifacts, and memories. The Historic Preservation Element outlines a number of specific programs for achieving the goal of historic preservation, including designating historic structures, sites and districts; promoting the retention of historic resources through a variety of incentives; and the continued maintenance of a Historic Master Plan.

The preservation policies set forth in the General Plan are implemented through the City's Historic Preservation Ordinance. A nine-member Historic Preservation Commission acts on all matters pertaining to promotion,

# National Historic Landmark District design guidelines

restoration, and protection of City of Monterey historic resources in accord with City ordinances or instruction from the City Council.

Also, there are State and Federal preservation programs that oversee National Historic Landmark Districts. They are noted briefly in this section.

## **Historic Master Plan**

The City's Historic Master Plan, adopted in 2000, establishes a framework for preserving and interpreting historic, archaeological and cultural resources in Monterey. The Plan has two main goals: 1) Integration of governments and non-profit historic preservation and interpretation efforts; and 2) Protection of historic resources (landscapes, sites, buildings, artifacts and memories). Objectives include: the coordination of efforts to make Historic Monterey a destination; making the City's history more comprehensible for its citizens; establishing a proactive program to preserve areas and resources of historic significance; conduct, maintain and update historic surveys; preserve historic landscapes; and develop and encourage interpretive programs and collection of artifacts and memories.

## **City of Monterey Historic Preservation Ordinance**

The City of Monterey's Historic Preservation Ordinance implements the General Plan Historic Preservation Element policies. The Ordinance outlines the process by which historic resources are identified and protected, thresholds for alteration and demolition, and property owner incentives for the protection of historic resources within the City. The Ordinance also requires that historic resource surveys, including the present Downtown Monterey survey, be reviewed every five years and updated as appropriate.

## **H-1 Landmark Overlay Zoning**

H-1 zoning is intended to identify and protect the most important historic resources in the City, generally including properties with statewide, national or international historic resources. The City recognizes its responsibility for preserving these resources for a national and international public, and the H-1 zone may be established without owner consent in order to fulfill that responsibility. The H-1 zone has a strong series of incentives to support and encourage preservation of historic resources. H-1 Landmark zoning may be applied only to properties that meet the National Register of Historic Places criteria as defined in National Register Bulletin 15, and to properties that are the first, last, only, rare, or most significant resources of its type in the region.



# National Historic Landmark District design guidelines

**For More Information:**  
See the web link to Secretary of  
the Interior's Standards for the  
Treatment of Historic Proper-  
ties web site:  
<http://www.nps.gov/tps/standards.htm>

## H-2 City Historic Resource Overlay Zoning

H-2 zoning is intended to identify and protect historic resources in the City that would be recognized as resources with local historic importance and their historic importance would not generally be recognized outside the immediate area of the Monterey Peninsula. The City encourages the preservation of these resources with a strong set of incentives; however, the decision to rezone and ultimately to preserve them is left to the property owner. H-2 City Resource zoning may only be applied to properties which meet National or California Register criteria.

## Secretary of the Interior's Standards for the Treatment of Historic Properties

The Secretary of the Interior has adopted standards for the treatment of cultural resources, which apply when federal actions are involved with properties listed in the National Register of Historic Places.

## National Historic Landmark District

National Historic Landmark Districts are places where prominent significant historical events occurred. They represent ideas that shaped the nation, that provide important information about our past, or that are outstanding examples of design or construction. The NHLD guidelines recognize these areas as special places of significance.

The Old Town National Historic Landmark District is recognized for its significance in the early settlement and development in California.

## State Program

The California Environmental Quality Act (CEQA) requires state and local public agencies to identify the environmental impacts of proposed discretionary activities or projects, determine if the impacts will be significant, and identify alternatives and mitigation measures that will substantially reduce or eliminate significant impacts to the environment. Historical resources are considered part of the environment and a project that may cause a substantial adverse effect on the significance of a historical resource is a project that may have a significant effect on the environment.

## Using the Design Guidelines

The design guidelines inform review of improvements to historic properties and new construction proposed within the Monterey Old Town National Historic Landmark Districts. They will be used by property owners, businesses, historic preservationists, and members of the community. This section provides a guide to using the design guidelines. It identifies where the guidelines apply, describes which design guidelines are relevant to different types of projects, lists the types of projects that will be reviewed and explains the format and use of individual guidelines.

# National Historic Landmark District design guidelines

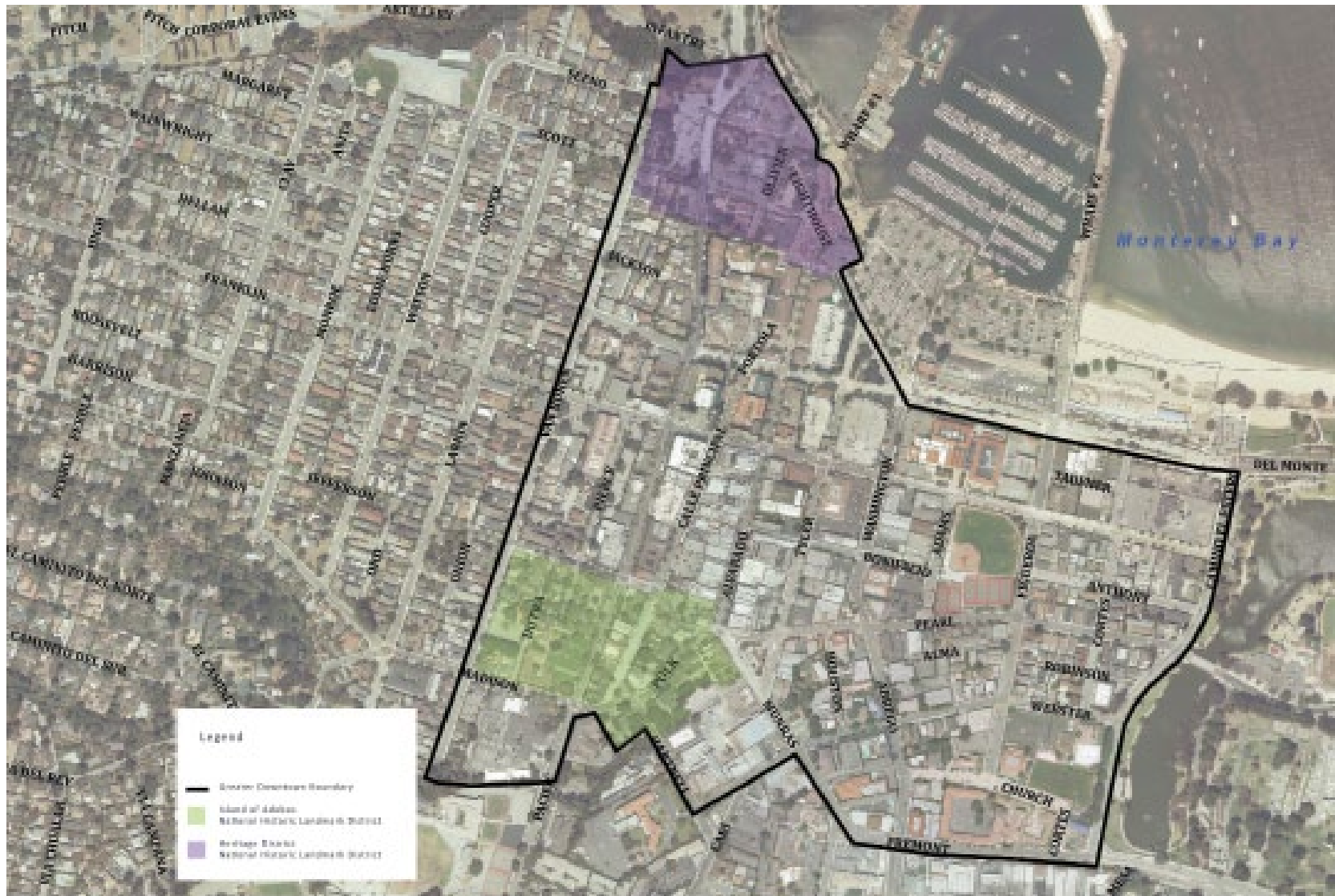

Figure 10: This map locates the Old Town NHLD within the Greater Downtown area. The guidelines apply to these districts.

# National Historic Landmark District design guidelines

**Which Chapters Apply to a Specific Project?**

The chart below indicates which chapters are most relevant to different types of work in the Old Town NHLD. Some projects will combine more than one type of work (i.e., a project including rehabilitation of a historic building and construction of a new building on an adjacent site), in which case a combination of chapters will apply.

Type of Work	Section	About the Design Guidelines	Sustainability - Social, Economic and Environmental Benefits of Historic Preservation	Planning a Preservation Project	Historical Background of the National Historic Landmark Districts	Development Patterns	Historic Architectural Styles	Treatment of Historic Resources	Design Guidelines for Historic and Non-Historic Properties	Miscellaneous Guidelines for both Historic and Non-Historic Properties	Design Guidelines for New Construction
Work on a historic property		✔	✔	✔	✔	✔	✔	✔	(1)	(1)	-
Alterations to a non-historic property		✔	-	-	✔	✔	-	-	(1)	(1)	(1)
Construct a new building		✔	-	-	✔	✔	-	-	(1)	(1)	✔
Miscellaneous		✔	-	-	-	-	-	-	-	✔	-

(1) Guidelines in these sections may apply to some projects in this category.

- Not Applicable

# National Historic Landmark District design guidelines

## Key Design Guidelines Components

The individual design guidelines in this document use a standard format with several key components. All components of the guideline are used in the design review process. The key components of a typical design guideline are illustrated below.

### Legend

#### **A** Design Topic

*Describes the design topic addressed by the design guidelines that follow.*

#### **B** Objective

*Explains the desired outcome for the design topic and provides a basis for the design guidelines that follow. If a guideline does not address a specific design issue, the objective will be used to determine appropriateness.*

#### **C** Design Guideline

*Describes a desired performance-oriented design outcome.*

#### **D** Additional Information

*Provides a bulleted list of suggestions on how to meet the intent of the design guideline.*

### Sample Guideline

#### **A** → Treatment of Character-defining Features and Architectural Details

**B** → Character defining features and architectural details contribute to the character of a structure. Specific details are associated with specific architectural styles and should be preserved.

#### **C** → 1.1 4.1 Preserve character-defining features.

- D** →
- Foundations, porches, verandas, shutters, columns, exposed rafter tails and clay tiles are examples of architectural features that should be preserved.
  - Preserve intact features with appropriate maintenance techniques; for example, caulking and repainting are important for wood windows.
  - Do not remove or alter features that are in good condition or that can be repaired.
  - Don't obscure significant features with coverings or signs.



*Protect and maintain significant stylistic features, such as these window features.*

# National Historic Landmark District design guidelines

## Sustainability - Social, Economic and Environmental Benefits of Historic Preservation

Preserving and enhancing historic places promotes the three basic components of sustainability. The three components are: (1) Cultural/Social Sustainability, (2) Environmental Sustainability and (3) Economic Sustainability. Each of the components is described in greater detail in the following pages.



*Preserving historic places promotes the three basic categories of sustainability.*

## Cultural/Social Component of Sustainability

This component of sustainability relates to the maintenance of the community's cultural traditions and social fabric. Preserving historic places and patterns promotes cultural and social sustainability by supporting everyday connections between residents and the cultural heritage of the community. These connections are reinforced by the physical characteristics of historic places, which often directly support environmental sustainability.

The historic properties in the district provide direct links to the past. These links convey information about earlier ways of life that help build an ongoing sense of identity within the community. Residents anchored in this sense of identity may be more involved in civic activities and overall community sustainability efforts.

The historic development pattern of the district promotes social interaction that supports a high quality of life and helps build a sense of community. The area is compact and walkable, providing for impromptu mixing of different cultural and economic groups. Direct connections to the public realm provide opportunities for community interaction. This physical pattern, combined with the inherent cultural connections, provides significant support for the community's overall sustainability effort.

# National Historic Landmark District design guidelines

## Environmental Component of Sustainability

This is the most often cited component of sustainability. It relates to maintenance of the natural environment and the systems that support human development. Rehabilitation of historic resources is an important part of environmental sustainability and green building initiatives. It directly supports environmental sustainability through conservation of embodied energy, adaptability, and other factors that keep historic buildings in use over long periods of time.

### Embodied Energy

Embodied energy is defined as the amount of energy used to create and maintain the original building and its components. Preserving a historic structure retains this energy. Re-using a building also preserves the energy and resources invested in its construction, and reduces the need for producing new construction materials, which require more energy to produce. Studies confirm that the loss of embodied energy by demolition takes three decades or more to recoup, even with the reduced operating energy costs in a replacement building.

### Building Materials

Many of the historic building materials used in the district contribute to environmental sustainability through local sourcing and long life cycles. Buildings constructed with adobe, wood and masonry were built for longevity and ongoing repair. Today, new structures utilize a

significant percentage of manufactured materials. These materials are often less sustainable and require extraction of raw, non-renewable materials. High levels of energy are involved in production, and the new materials may also have an inherently short lifespan.

The sustainable nature of historic building materials is best illustrated by a residential window. Older windows were built with well seasoned wood from durable, weather resistant old growth forests. A historic window can be repaired by re-glazing as well as patching and splicing the wood elements. Many contemporary windows cannot be repaired and must be replaced entirely. Repairing, weather-stripping and insulating an original window is generally as energy efficient and much less expensive than replacement.

### Landfill Impacts

According to the Environmental Protection Agency, building debris constitutes around a third of all waste generated in the country. The amount of waste is reduced significantly when historic structures are retained rather than demolished.

# National Historic Landmark District design guidelines

## Economic Component of Sustainability

This component of sustainability relates to the economic balance and health of the community. The economic benefits of protecting historic resources are well documented across the nation. These include higher property values, job creation in rehabilitation industries, and increased heritage tourism. Quality of life improvements associated with living in historic neighborhoods may also help communities recruit desirable businesses.

## Historic Rehabilitation Projects

Historic rehabilitation projects generate both direct and indirect benefits. Direct benefits result from the actual purchases of labor and materials, while material manufacture and transport results in indirect benefits. Preservation projects are generally more labor intensive, with up to 70% of the total project budget being spent on labor, as opposed to 50% when compared to new construction. Expenditure on local labor and materials benefits the community's economy.

### *For More Information:*

*See web link to National Park Service Sustainability information:*

*<http://www.nps.gov/tps/sustainability.htm>*

*See web link to Sustainability guides from the California State Parks Office of Historic Preservation:*

*[http://ohp.parks.ca.gov/?page\\_id=24592](http://ohp.parks.ca.gov/?page_id=24592)*

# National Historic Landmark District design guidelines

## Planning a Preservation Project

This section establishes the theoretical principles for preservation, and provides steps to follow in planning an improvement project. It translates basic theory from the Secretary of the Interior's Standards into laymen's terms. This will help property owners chart an

appropriate approach for improving a historic property, and it provides a reference of basic theory for staff and the commission to use in their reviews as well.

## General Preservation Principles

### Respect the historic character of a property.

- The basic form and materials of a building, as well as its architectural details, are a part of the historic character.
- Do not try to change the style of a historic resource or make it look older than its actual age.
- Confusing the character by mixing elements of different styles or periods can adversely affect the historic significance of the property.

### Seek uses that are compatible with the historic character of the property.

- Converting a building to a new use different from the original use is considered to be an "adaptive reuse," and is a sound strategy for keeping a building in service. A good adaptive use project retains the historic character of the building while accommodating a new function.
- Every reasonable effort should be made to provide a compatible use for the building that will require minimal alteration to the building and its site.
- Changes in use requiring the least alteration to significant elements are preferred. In most cases designs can be developed that respect the historic integrity of the building while also accommodating new functions.



# National Historic Landmark District design guidelines

*Each project should comply with these General Rehabilitation Principles.*

## Maintain significant features and stylistic elements.

- Distinctive stylistic features and other examples of skilled craftsmanship should be preserved. The best preservation procedure is to maintain historic features from the outset to prevent the need for repair later. Appropriate maintenance includes rust removal, caulking and repainting.
- These features should not be removed.

## Repair deteriorated historic features and replace only those elements that cannot be repaired.

- Upgrade existing materials, using recognized preservation methods whenever possible. If disassembly is necessary for repair or restoration, use methods that minimize damage to original materials and facilitate reassembly.

# National Historic Landmark District design guidelines

## Planning a Preservation Approach

When planning a preservation project, it is important to determine the significance of the property and the degree to which it retains its integrity as a historic resource. Next, a specific approach to the overall treatment of the property should be established. This may include keeping the building in its current character, while making appropriate repairs, or incorporating new, compatible changes. It is then important to determine how surviving historic features will be treated. This may include preserving those features that remain intact, repairing those that are deteriorated and replacing others. Preservation project steps are summarized below.

### Step 1: Review Reasons for Significance

Understanding the history of a building is important to any preservation project. Survey information should be consulted to help identify the building's key features and its period of significance. This will help determine to what degree the property should be preserved as it is, or where there may be opportunities for compatible alterations to occur. *See: Architectural Resources Group, National Historic Landmark District and Downtown Area Context Statement and Reconnaissance Survey, Monterey, California, September 2011.*

### Step 2: Determine Building Integrity

The condition of a building and its features contribute to the overall significance of the building. A building with historic integrity has a sufficient percentage of key character-defining features and characteristics from its period of significance which remain intact. These key elements allow a building to be recognized as a product of its time.

### Step 3: Identify Program Requirements

The functional requirements for the property drive the work to be considered. If the existing use will be maintained, then preservation will be the focus. If changes in use are planned, then some degree of compatible alterations may be needed.

### Step 4: Implement a Treatment Strategy

A preservation project may include a range of activities, such as maintenance of existing historic elements, repair of deteriorated materials, the replacement of missing features and construction of a new addition. While the term "preservation" is used broadly to mean keeping a historic property's significant features, it is also used in a more specific, technical form to mean keeping a resource in good condition. This and other related terms are important to understand because they are all used when planning for improvements to a historic resource. Also note, that while an overall treatment for the building may be used, a different treatment may be applied to a specific building component (See the following section for more information).

# National Historic Landmark District design guidelines

*Each project proposal should include information from these four steps.*

## Steps to Consider for a Successful Preservation Project



**Step 1. Review reasons for significance:** The reasons for significance will influence the degree of rigor with which the guidelines are applied, because it affects which features will be determined to be key to preserve. Identifying the building's period of significance is an important part of this first step.



**Step 2. Determine Building Integrity:** A historic property has integrity. It retains a sufficient percentage of key character-defining features and related characteristics from its period of significance.



**Step 3. Identify Program Requirements:** The functional requirements for the property drive the work to be considered. If the existing use will be maintained, then preservation will be the focus. If changes in use are planned, then some degree of compatible alterations may occur.



**Step 4. Implement a Treatment Strategy:** An appropriate treatment strategy will emerge once historic significance, integrity and program requirements have been determined. A preservation project may include a range of activities, such as maintenance of existing historic elements, repair of deteriorated materials, the replacement of missing features and construction of a new addition.

# National Historic Landmark District design guidelines

## Accepted Treatments For Historic Resources (The Secretary of the Interior's definitions)

The following list describes appropriate treatments for historic resources that may be considered when planning a preservation project. Much of the language addresses buildings; however, sites and structures are also relevant.

**Preservation** is the act or process of applying measures to sustain the existing form, integrity and material of a building. Some work focuses on keeping a property in good working condition by repairing features as soon as deterioration becomes apparent, using procedures that retain the original character and finish of the features. Property owners are strongly encouraged to maintain properties in good condition.

**Restoration** is the act or process of accurately depicting the form, features and character of a property as it appeared in a particular time period. It may require the removal of features from outside the restoration period.

**Rehabilitation** is the process of returning a property to a state that makes a contemporary use possible while still preserving those portions or features of the property which are significant to its historical, architectural and cultural values. Rehabilitation may include a change in use of the building or additions. This term is the broadest of the appropriate treatments and is often used in the guidelines with the understanding that it may also involve other appropriate treatments.

**Reconstruction** is the act or process of depicting, by means of new construction, the form, features and detailing of a non-surviving site, landscape, building, structure or object for the purpose of replicating its appearance at a specific time and in its historic location.

**Combining Treatments.** For many projects a “rehabilitation” approach will be the overall strategy. Within that however, there may be a combination of treatments used as they relate to specific building components. For example, within an individual project a surviving porch may be preserved, a stucco wall may be restored, and a missing window may be reconstructed.

# National Historic Landmark District design guidelines

## Inappropriate Treatments

The following approaches are not appropriate for historically significant properties.

**Remodeling** is the process of changing the historic design of a building. The appearance is altered by removing original details and by adding new features that are out of character with the original. Remodeling of a historic structure is inappropriate.

**Deconstruction** is the process of dismantling a building such that the individual material components and architectural details remain intact. This may be employed when a building is relocated or when the materials are to be reused in other building projects. Deconstruction may be a more environmentally responsible alternative to conventional demolition. However, it is an inappropriate treatment for a building of historic significance.

**Demolition** is an act or process that destroys, in part or whole, a structure, building or site. This is inappropriate for any historic building.

**Adding false historical features** is the process of adding a false historic feature that can confuse the interpretation of the building. Adding historic features is inappropriate.

## Preferred Sequence of Actions

Selecting an appropriate treatment for individual character-defining features of a historic building will provide for proper preservation of the historic fabric. The method that requires the least intervention is always preferred. By following this tenet, the highest degree of integrity will be maintained. The following treatment options appear in order of preference. When making a selection, follow this sequence:

**Step 1. Preserve:** If a feature is intact and in good condition, maintain it as such.

**Step 2. Repair:** If the feature is deteriorated or damaged, repair it to its original condition.

**Step 3. Replace:** If it is not feasible to repair the feature, then replace it in kind, (e.g., materials, detail, finish). Replace only that portion which is beyond repair.

**Step 4. Reconstruct:** If the feature is missing entirely, reconstruct it from appropriate evidence. Also, if a portion of a feature is missing, it can also be reconstructed.

**Compatible Alterations:** If a new feature (one that did not exist previously) or an addition is necessary, design it in such a way as to minimize the impact on original features. It is also important to distinguish new features on a historic building from original historic elements, even if in subtle ways.

# National Historic Landmark District design guidelines

## Historical Background of the National Historic Landmark Districts

This section provides a brief history of Monterey, with a focus on the physical development patterns in the downtown, particularly as it relates to the National Historic Landmark Districts. It is adapted from the document, National Historic Landmark District and Downtown Area Context Statement and Reconnaissance Survey, Monterey, California, prepared by Architectural Resources Group in September 2011. Their history of downtown Monterey consists of several periods of development. These periods are summarized in the following pages:

- Spanish Monterey (1542-1821)
- Mexican Monterey (1821-1846)
- Early American Monterey (1846-1879)
- Victorian Monterey (1880-1899)
- Early Twentieth Century Expansion of Monterey (1900-1939)

(Note that the full context document also includes the area's first inhabitants and later periods from the mid-Twentieth century, but they are not included here because they are not represented by historic structures in the NHLD.)

### Spanish Monterey (1542-1821)

Spanish explorers traveled through the Monterey area in the 1500s and 1600s. Formal settlement began on June 3, 1770, when Jose Maria Soberanes and Juan Bautista Alvarado joined Father Serra and other men in their party in the formal dedication of the Presidio of Monterey and Mission San Carlos Borromeo.

In the early 1770s, all of the population of Monterey lived within the stockade of the Spanish presidio, which occupied most of the area bounded today by the streets of Camino El Estero, Webster, Figueroa and Fremont. A variety of buildings sat along the walls, including a chapel, store-houses, offices, soldier's barracks, and residences. Most of these structures were initially built of upright poles, logs and tule, although a few were of adobe.



*Larkin House, 510 Calle Principal (1835) dates from the Mexican Monterey period.*

**For More Information:**  
See web link to Old Town  
NHLD Draft Context Statement and Survey:  
<http://www.monterey.org/en-us/departments/planspublicworks/planning/planning-projects/newmontereyhistoric-survey.aspx>

# National Historic Landmark District design guidelines

In 1776, Viceroy Bucareli, in recognition of the growing importance of Alta California, ordered the transfer of the seat of government to Monterey, making it the official capital of Baja and Alta California. During this time, tile and stone were introduced, and the new buildings established the mission style of architecture.

In 1794, the stone Royal Presidio Chapel was completed. It is the only remaining structure associated with the Spanish Period theme in the downtown and is a National Historic Landmark. It is the oldest building in Monterey and is the oldest structure in California built of cut stone.

## Mexican Monterey (1821-1846)

Mexico gained its independence from Spain in 1821, and it continued to govern the region with the Presidio of Monterey as the capital. Foreign trade expanded and Monterey became California's official port of entry in 1831. This period was marked by the construction of the Custom House, where duties were paid by vessels trading with the Mexican territory of Upper California, and by the arrival of Yankee entrepreneurs.

Monterey's role as a commercial hub began in 1822 with Hugh McCulloch and William E. P. Hartnell. They built a warehouse and shop to conduct business. Another entrepreneur, Thomas Oliver Larkin, became Monterey's most prominent merchant of the period. He built the first wharf in Monterey, established the first non-military hospital, and served as the first and last United States consul from 1843 to 1848.

Thomas Larkin also oversaw a series of enlargements to the Custom House from 1841 to 1846, resulting in the building's present appearance, with a two-story north wing, one-story central portion, and two-story south wing. He also designed his own home, which exhibited a New England influence.

New settlement shifted from the Spanish-era Alta Mesa neighborhood on the highlands south of the presidio to the flatlands near the Custom House. New homes and businesses oriented along north-south paths that would become Alvarado Street, Callé Principal and Pacific Street.

Properties of historic significance from this era include the Alvarado Adobe at 490-498 Alvarado Street, which served as the office of Juan Bautista Alvarado during his term as governor of California from 1836 to 1842 as well as the Custom House, the earliest portion of which dates from the late 1820s and the Casa del Oro.

Properties from the Mexican period are built of adobe and are generally of two interrelated styles: an earlier, simpler style associated with the Spanish Colonial Empire, and a later, more complex style that incorporated influences from the Eastern United States.

The adobe house that Thomas Larkin built soon after his arrival from Boston marked a significant turning point in California's colonial architecture. Utilizing the skilled labor of Scotch and Irish immigrants from Yankee and British ships, Larkin began construction of his home in 1835. Though built of adobe brick, a strong redwood

# National Historic Landmark District design guidelines

frame made possible an upper story, as well as more freedom in the placement of windows. The design also incorporated some elements from the Southern plantation. From the Eastern American colonial pattern came the floor plan, interior staircase, and hipped roof covered with shingles. But the verandas, built to protect the walls from water erosion, were reminiscent of the Southern plantation. The Larkin House established a new style of architecture – the Monterey Colonial.

The Custom House also serves as an interesting case study, within a single building, of the differences between the Spanish Colonial and Monterey Colonial styles. The oldest portion of the building (the north half of the central one-story structure) was built in the late 1820s in the Spanish Colonial style. In the 1840s, Thomas Larkin oversaw the expansion of the one-story portion and the addition of the two story portions at the building's north and south ends. With their hipped-roofs and two-story verandas, these additions are strongly Monterey Colonial. It should be noted that Spanish Colonial and Monterey Colonial styles were often combined, especially as modifications were made to older buildings.

## Early American Monterey (1846-1879)

Conflicts in Texas led Mexico and the United States to declare war in May 1846, and resulted in the seizing of Monterey harbor and installing an American fort. During the period of military rule, each California community was governed by an alcalde. The most powerful and influential alcalde was that of Monterey, a post occupied from July 1846 to August 1849 by Walter Colton. Colton's most enduring and remarkable achievement was the construction in 1849 of the town hall that bears his name. Built of white stone quarried from a neighboring hill, Colton Hall was graceful in style and ornamented with a portico. As a civic building, Colton Hall was without rival in the California of its time.



*Old Whaling Station, 125 Pacific Street (1847) dates from the Early American Monterey period.*



# National Historic Landmark District design guidelines

The discovery of gold in 1848 brought thousands of Americans to California, increasing pressure for admission to the Union. U.S. Brigadier General Bennett Riley issued the call in June 1849 for a California state constitutional convention, to be held at Colton Hall. This subsequently led to California's admission to statehood.

Monterey remained small throughout the remainder of the nineteenth century, while the population of California grew. However, it continued as an economic center for a region that included the Carmel and Salinas Valleys, along with Big Sur, Castroville and San Juan Bautista.

Monterey's whaling industry had begun in 1854 by Captain Davenport's whaling company. By 1861, four companies hunted Humpback and California Gray whales in Monterey Bay. Captain Davenport's company operated out of Jack Swan's adobe, now known as California's First Theater (202 Pacific Street). The Whaling Station (125 Pacific Street) was home to the Old Monterey Whaling Company, a group of seventeen Portuguese whalers. For years, each company produced approximately one thousand barrels of oil annually. By the late 1870s, however, shore whaling had become less common as both the whale populations and the demand for whale oil decreased.

## Monterey's Evolving Street Network

Much of downtown Monterey's current street network was established during this time. Alvarado Street extended from the Custom House southward approximately one-third of a mile to the town plaza and water pump at Pearl Street. By 1875, Monterey's business district radiated outward from this center. The central spine of commercial establishments extended northward along Alvarado Street. At the street's south end, the block bound by Houston, Webster, California (now Munras Avenue) and Pearl Streets included a second concentration of businesses, along with El Cuartel and the old Spanish jail.

## Historically Significant Properties from this Period

Properties within the downtown area from this period include several contributors to the Old Town Monterey National Historic District. These contributing properties date from Monterey's stint as territorial capital of American California, or from the years immediately thereafter. Note that many of the significant properties from this period were built prior to 1846 but played important roles in early American Monterey.

# National Historic Landmark District design guidelines

## Historic properties from this era include:

- Osio-Rodriguez Adobe, 380 Alvarado Street (1849)
- Larkin House, 510 Calle Principal (1835)\*
- Sherman's Headquarters, 510 Calle Principal (1834)\*
- Custom House, 1 Custom House Plaza (1820s/1840s)\*
- Pacific House, 8 Custom House Plaza (1847)\*
- First Federal Courthouse/Gabriel de la Torre Adobe, 509 Hartnell Street (1841)\*
- Casa del Oro, 200 Olivier Street (1845)\*
- California's First Theater, 202 Pacific Street (1845/1847)\*
- Colton Hall, 570 Pacific Street (1849)\*
- Miller Adobe, 580 Calle Principal (1874)
- 520 Dutra Street (1874)
- 526 Dutra Street (1874)
- Fremont Adobe, 539 Hartnell Street (1850)\*
- Stevenson House, 530 Houston Street (1840)
- Duarte Store, 220 Olivier Street (1865)
- Thomas Cole House, 230 Olivier Street (1856)\*
- First Brick House, 125 Pacific Street (1847)\*
- Old Whaling Station, 125 Pacific Street (1847)\*

\* Properties marked with an asterisk are contributors to the Old Town Monterey National Historic Landmark District.

Stylistically, the properties within this period either represent a continuation of the Spanish Colonial and Monterey Colonial styles that were already well established in Monterey, or represent one of several Period Revival styles popular in the second half of the nineteenth century.



*California's First Theater, 202 Pacific Street (1845/1847)*

# National Historic Landmark District design guidelines

## Victorian Monterey (1880-1899)

During the late Nineteenth Century, railroads expanded in Monterey and facilitated shipment of goods and also provided access for tourists to the area. Commercial development continued, with buildings filling in between the concentration around the Customs House and those that were clustered around the town plaza at Alvarado and Pearl Streets. Historically significant properties from this period lie outside the two National Historic Landmark boundaries, but do contribute to the character of the downtown at large. Many of these are wood frame residential structures.

## Early Twentieth Century Expansion (1900-1939)

This era saw the rise of the sardine fishing and canning industries. This included two wharves at the end of Alvarado and Figueroa Streets. While much of the development related to fishing occurred in the Cannery Row area, development downtown also continued, in response to the demand for goods and services for residents and employees that this growth brought.

The military also expanded during this period, notably with the creation of Fort Ord. This contributed significantly to the region's economy and the development in downtown. A growing number of artists also located in the area during this time. John Steinbeck was among them; he took up residence in the Lara-Soto adobe in 1944, adding a new layer of historic significance to this and other properties in the area.

Many properties from this period exist that have historic significance, but most are outside of the NHLDs.

# National Historic Landmark District design guidelines

## Development Patterns

Early photographs document a mix of settings and building types, including stores, residences, outbuildings, a theater and governmental buildings in what is now the NHLD. These resources still exist today and define this remarkable district. They establish the context for the design of new infill buildings and site improvements.

The design features of the NHLD can be described in three general levels of perception. In the first category, features that are of a “neighborhood-wide” nature are grouped. These address ways in which the system of streets and open spaces are organized, and the manner in which properties relate to each other. In the second category, site design characteristics are described. These include the way in which an individual building is located on a parcel, as well as the arrangement of open space and any landscaping that may exist. Finally, the third category describes the characteristics of historic buildings themselves.

## Neighborhood-wide Features

The basic organization of streets, the layout of lots and the system of open spaces and views are features that extend beyond individual properties and establish an underlying framework for development in the district.

## Street Patterns

Some basic relationships were established with the evolution of streets in the area. Early maps document

a rather random arrangement of buildings, some generally along what were to become streets. Historic photographs show that, later in time, a more formal arrangement emerged, and these streets generally followed an orthogonal grid, with the exception of Pacific Street that shifts in the northern district (Heritage District) and Madison and Polk in the south district. These create some signature lots where these streets intersect with the grid.

Cross streets define the edges of the southern district (Island of Adobes). Some city blocks in the Island of Adobes are only one lot deep, with frontages on two streets. This merits special consideration when planning for any infill in this area. The grid pattern has been obscured somewhat in the Heritage District, where some streets have been closed and new open spaces created. This may offer opportunities to express the original street pattern in future development, in the way in which buildings are sited and pathways are established.

Some key open spaces merit note. The central plaza of the Heritage District is a more recent feature, but it exists where Callé Principal and Alvarado Streets once intersected, and to some extent reflects the gathering space that this once was. In the Island of Adobes, the park in front of Colton Hall is a signature space. While landscape details have changed over time, this continues to represent the character that has been the foreground for this important civic building.

# National Historic Landmark District design guidelines

## Site Design Features

### Orientation to the Street

Most primary structures face the street. In some cases, where there are through-lots, a garden wall or secondary building may define the rear property line along another street. And, in some cases, buildings are freestanding in a major open space. The Custom House is an example. This changes the pattern of building orientation along this street.

### Building Setbacks

Variation in the “building wall” occurs along many of the streets in both parts of the NHLD, with commercial buildings frequently aligning at the sidewalk edge, while residential and civic structures sit back from the street, with a lawn in front. Along Polk Street and Callé Principal, more of the buildings align at the sidewalk in a way that is similar to other traditional commercial streets in downtown Monterey. Single-family residential buildings are different since they typically have front yards and setbacks tend to be 15 to 20 feet.

### Open Space & Landscape

Formal and informal landscapes and open spaces occur in plazas, courtyards and front yards. Formal landscapes and plazas are associated with historic civic buildings. In residential settings, some yards are fenced or walled. These typically convey a handcrafted quality, and may be accented with small details of

craftsmanship, such as a wrought fence handle, a decorative tile, or wall-mounted light. Many have ornamental shrubs and flowerbeds within.

## Features of Key Building Types

The NHLD exhibits a long tradition of diverse but similar buildings types, often located in close proximity to one another. Nonetheless, a general sense of visual continuity exists because most buildings use a limited palette of materials, forms and massing.

### Building Materials

A limited range of building materials exists, with some more prevalent than others. Stucco and plaster finished structures are predominant. These include the



*Formal and informal landscapes and open spaces occur in plazas, courtyards and front yards throughout the district.*

# National Historic Landmark District design guidelines



*Roof forms are varied, although gable and hip roofs are predominant. Note the clipped roof form on the Custom House.*

early adobe buildings as well as later revival styles that emulate this tradition. Wood frame buildings also occur, typically clad with horizontal lap siding. Masonry is found, mostly as a foundation material, although a few examples exist of brick and stone as primary materials.

## **Varied Roof Forms**

Roof forms are varied, although gable and hip roofs are predominant. Shed and flat roofs were also seen. Some roofs appeared flat from the street, because they were concealed by parapets that were often shaped decoratively and detailed three-dimensionally. Roof materials included wood shingle, clay tile and asphalt shingles.

# National Historic Landmark District design guidelines

## Variation in Mass

Most buildings have a simple, rectangular form, but often this may be supplemented with smaller building wings or modules that provide variety in massing. In each case, however, one central form predominates.

## Character of the Street Wall

In many blocks, a relatively uniform alignment of building fronts occurs at the sidewalk edge. At the street level, visual interest is provided by windows and doors, porticoes, and decorative detailing. However, this is always subordinate in nature to the simple massing and basic building materials that are a part of all buildings in the area.

While building setbacks may vary, there is a strong tradition of designing all the way to the street edge. Where buildings are not at the front property line, fences and hedges define the sidewalk edge instead.

All of these key features of the NHLD should be taken into consideration when designing a new building or planning site improvements. The guidelines that follow include references to these features and provide more specific direction for compatible new construction.

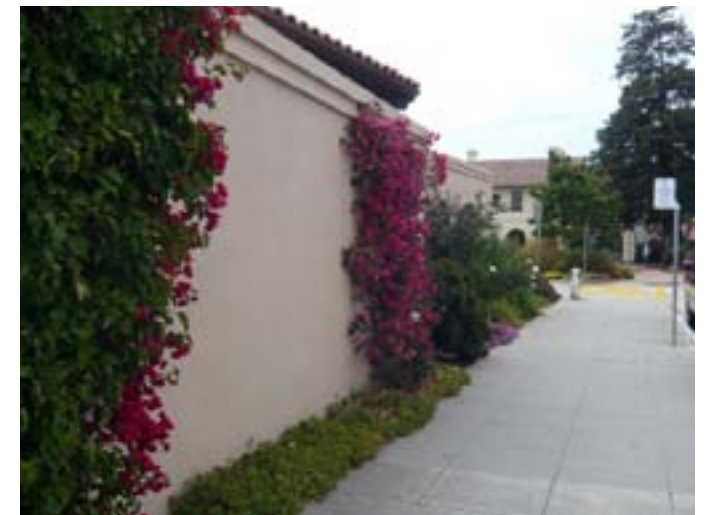

*While building setbacks may vary, there is a strong tradition of designing all the way to the street edge. Where buildings are not at the front property line, fences and hedges define the sidewalk edge instead.*

# National Historic Landmark District design guidelines

## Historic Architectural Styles

This section provides an illustrated summary of typical historic resources that exist in the Old Town National Historic Landmark District, generally focusing on building types, but also includes a description of site features and landscapes. This establishes an understanding of the “character-defining features” of these property types, which is information that is then used when applying the guidelines.

*The styles are adapted from the document, National Historic Landmark District and Downtown Area Context Statement and Reconnaissance Survey, Monterey, California, prepared by Architectural Resources Group in September 2011.*



California's First Theater (1845/1847)

### Spanish Colonial

Character-defining features of the Spanish Colonial style include:

- Thick adobe walls covered with mud plaster and whitewash coating
- Minimal ornamentation
- One-story (sometimes two) height
- Rectangular floor plan with single row of rooms
- Side-gable roof clad in clay tiles
- Small, often deep-set window openings
- Adjoining patio or walled-in area
- Stone foundation

#### *For More Information:*

*See web link to Old Town NHLD Draft Context Statement and Survey:*

*<http://www.monterey.org/en-us/departments/planspublicworks/planning/planningprojects/newmontereyhistoricsurvey.aspx>*



# National Historic Landmark District design guidelines



Old Whaling Station (1847)

## Monterey Colonial

Character-defining features of the Monterey Colonial style include:

- Thick adobe walls covered with mud plaster and whitewash coating
- Minimal ornamentation
- Two-story height
- Two-story veranda or cantilevered balcony
- Hipped roof clad in tiles or shingles
- Wood frame windows
- Interior hallways and stairs
- Adjoining patio or walled-in area
- Stone foundation



Gordon House (1849) 526 Pierce

## French Colonial

Character-defining features of the French Colonial style include:

- One-story height
- Extensive porch supported by wood columns under main roof line
- Multi-lite, double-sash wood windows
- Paired wood shutters at window and door openings
- Hipped roof

# National Historic Landmark District design guidelines



First Brick House (1847)



St. James Episcopal/O'Donnell Library (1860-altered)

## Colonial Revival

Character-defining features of the Colonial Revival style include:

- Side gabled roof
- Multi-lite, double-sash wood windows, often with wood shutters
- One or two-story height
- Small or no entry porch

## Gothic Revival

Character-defining features of the Gothic Revival style include:

- Steeply-pitched, gable roof
- Narrow windows with pointed arch shape
- Wood cladding, either horizontal or board-and-batten
- Symmetrical facade

# National Historic Landmark District design guidelines



Colton Hall (1849)

## Greek Revival

Character-defining features of the Greek Revival style include:

- Rectangular plan
- Symmetrical facade
- Gable roof featuring gable returns
- Entry portico with columns supporting a gable roof
- Wide frieze or trim at the roofline



Perry-Downer House (1860-altered) 201 Van Buren

## Queen Anne

Character-defining features of the Queen Anne style include:

- Tall, vertical massing, often with turrets or towers in two-story examples
- Complex roof forms, often gabled and hipped
- Decorative brackets at boxed eaves
- Leaded glass
- Three-sided bay windows
- Partial-width or wraparound porches, often with decorative spindel posts and friezes
- Paired or single doors, often with sidelights and transoms
- Wood siding, often a combination of clapboard and decorative shingles

# National Historic Landmark District design guidelines



527 Van Buren Street (1892)

## Victorian Folk

Character-defining features of Folk Victorian building:

- Wood frame construction
- Gable or hipped roof
- Wood cladding, few with stucco
- Wood ornamentation
- Wood-sash windows (typically double-hung)
- One - two story height
- Set-back from lot line



## Vernacular Cottage

Common character-defining features of Vernacular Cottage building:

- Wood frame construction
- Gable or hipped roof
- Wood cladding, few with stucco
- Wood-sash windows (typically double-hung)
- One story height
- Set-back from lot line

# National Historic Landmark District design guidelines



571 - 579 Polk Street(1905)



540 Calle Principal Monterey Civic Club (1930)

## Craftsman Bungalow

Common character-defining features of the Craftsman Bungalow include:

- One to one-and-a-half stories in height
- Wood sash windows
- Leaded glass
- Windows arranged in bands
- Square or battered porch supports
- Single door entrances, often with glazing
- Hipped or gable low pitched roofs
- Wide overhanging eaves with exposed rafters and purlins
- Wood clapboard and/or wood shingle siding
- Use of rubble stone at foundation and porch rail/supports

## Spanish Colonial Revival

Common character-defining features of the Spanish Colonial Revival include:

- One to one-and-a-half stories in height
- Wood sash windows
- Leaded glass
- Rectangular floor plan with single row of rooms
- Side-gable roof clad clay tiles or shingles
- Deep set window openings
- Thick adobe walls covered with mud plaster and whitewash coating
- Stone foundation

# National Historic Landmark District design guidelines

## Properties

This section focuses on rehabilitation treatments and also addresses additions, as well as other special considerations related to historic properties. It “reflects” accepted principles for preservation, based on the Secretary’s Standards, to describe how they apply to individual building components.



*Preserve character-defining features, such as window and porch details.*

## Treatment of Character-defining Features and Architectural Details

Character defining features and architectural details contribute to the character of a structure. Specific details are associated with each architectural style.

### 1.1 Preserve character-defining features.

- Foundations, porches, verandas, shutters, columns, exposed rafter tails and clay tiles are examples of architectural features that should be preserved.
- Preserve intact features with appropriate maintenance techniques; for example, caulking and repainting are important for wood windows.
- Do not remove or alter features that are in good condition or that can be repaired.
- Don't obscure significant features with coverings or signs.

### For More Information:

See web link to *Preservation Brief 17 Architectural Character-Identifying the Visual Aspects of Historic Buildings as an Aid to Preserving Character.*

<http://www.nps.gov/tps/how-to-preserve/briefs/17-architectural-character.htm>

# National Historic Landmark District design guidelines

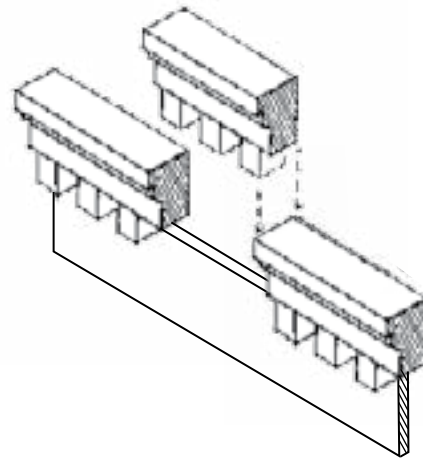

*Patch, piece-in, splice, consolidate or otherwise upgrade existing materials, using recognized preservation methods.*

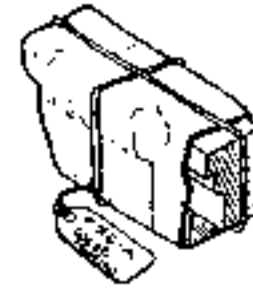

*When removing a historic feature for repair, document its location so it may be repositioned accurately.*

## **1.2 Repair deteriorated features.**

- Patch, piece-in, splice, consolidate or otherwise upgrade existing materials, using recognized preservation methods.
- Isolated areas of damage may be stabilized or fixed using consolidants. Epoxies and resins may be considered for wood repair.
- Removing a damaged feature that can be repaired is not appropriate.
- Protect significant features that are adjacent to the area being worked on.

## **1.3 Avoid adding details that were not part of the original building.**

- For example, decorative millwork should not be added to a building if it was not an original feature. Doing so would convey a false history.

## **1.4 Replace features that are missing or beyond repair accurately.**

- Reconstruct only those portions that are beyond repair.
- The design should be substantiated by physical or pictorial evidence to avoid creating a misrepresentation of the building's history.
- Use the same kind of material as the original when feasible.
- An alternative material may be acceptable if the size, shape, texture and finish conveys the visual appearance of the original. Alternative materials are usually more acceptable in locations that are remote from view or direct contact.

# National Historic Landmark District design guidelines



*Protect masonry and adobe from rising damp. Avoid irrigation systems that introduce water to foundations.*



*Preserve original building materials.*

## Materials and Finishes

Preserving original building materials and limiting replacement to only pieces which are deteriorated beyond repair is a key component of preservation. It also reduces the demand for, and environmental impacts from, the production of new materials and thus is sound sustainability policy. Primary historic building materials in the NHLD include wood, stone, brick, adobe and plaster.

### 1.5 Preserve original building materials.

- Avoid removing original materials that are in good condition.
- Remove only those materials which are deteriorated, and must be replaced.

### 1.6 Repair deteriorated primary building materials.

- Repair by patching, piecing-in, consolidating or otherwise reinforcing the material.

### 1.7 Match the original material used on primary surfaces in composition, scale and finish when their replacement is necessary.

- For example, if the original material is stucco, then the replacement material should be stucco as well. It should match the original in content, application (number of layers), color, finish and content.

Note that some early adobe materials may be of such significance that repairing may not be the best treatment, unless the underlying material is susceptible to damage.



# National Historic Landmark District design guidelines

- Replace only the amount of material required. If a few small areas are damaged then only they should be addressed, not the entire wall.
- Do not use synthetic materials, such as vinyl siding, or modular materials, such as panelized brick as replacement for primary building materials.

## 1.8 Do not cover original building materials.

- Vinyl siding, aluminum siding and synthetic stucco are inappropriate on historic buildings. Other imitation materials that are designed to look like historic materials, are also inappropriate.
- If a property already has a non-historic building material covering the original, it is not appropriate to add another layer of new material, which would further obscure the original.

## 1.9 Consider removing later covering materials that have not achieved historic significance.

- Once the non-historic siding is removed, repair the original, underlying material.
- If a structure has an inappropriate finish, removing the covering may be difficult, and may not be desirable. Test the material to assure that the original material underneath will not be damaged.



*If an exterior material is to be repaired, match the original material used. For example, if the original material is adobe, then the replacement material should be adobe as well. It should match the original in content, application, color, finish and content.*



*Do not cover original building materials with new materials.*

# National Historic Landmark District design guidelines

## Adobe

Adobe is a masonry-like material. Historically, adobe was developed on site by mixing together a variety of nearby natural materials. This included soil, water and binders (i.e., grasses, weeds and other refuse). The material was then set in block molds and dried in the sun. The blocks were used to build the walls of the structure and were assembled in courses with a layer of mud mortar. The adobe walls were typically finished with a surface coating.

These guidelines apply in addition to the more general materials and finishes guidelines section.

### 1.10 Protect adobe materials from deterioration.

- Provide proper drainage away from the foundation and walls.
- Remove sources that cause deterioration, such as water from sprinklers and landscaping.
- Maintain appropriate protective surface coatings. For example, avoid the use of elastomeric paints which can cause deterioration of adobe surfaces.
- When repairing adobe walls, use the same material with a similar compositional mix as the original when feasible.

### 1.11 Employ a maintenance program to keep adobe materials and finishes in good condition.

- A thorough investigation of the original material should be undertaken before repairs are addressed.
- Seek the advice of a professional with experience in preserving historic adobe structures following National Park Service criteria.



*Protect adobe materials from deterioration.*

### For More Information:

See web link to *Preservation Brief 5 Preservation of Historic Adobe Structures*:

<http://www.nps.gov/tps/how-to-preserve/briefs/5-adobe-buildings.htm>

# National Historic Landmark District design guidelines

## Masonry

Masonry includes stone, brick, terra cotta and concrete. These exist as building foundations, walls, site walls, steps and walkways. These guidelines apply in addition to the more general materials and finishes guidelines section.

### 1.12 Brick or stone that was not painted historically should not be painted.

- Some masonry naturally has a water-protective layer, or patina, to protect it from the elements. Painting masonry walls can seal in moisture already in the masonry, thereby not allowing it to breathe and causing extensive damage over the years.

### 1.13 Repoint mortar joints where there is evidence of deterioration.

- Duplicate the old mortar in strength, composition, color and texture.
- Avoid using mortar with a high portland cement content, which will be substantially harder than the original.
- Duplicate the mortar joints in width and profile.

### 1.14 Preserve significant concrete features.

- Examples are walls, steps, chimneys and foundations.



*Repoint mortar joints where there is evidence of deterioration.*

#### For More Information:

See web link to *Preservation Brief 1 Cleaning and water repellent Treatments for Historic Masonry Buildings*:

<http://www.nps.gov/tps/how-to-preserve/briefs/1-cleaning-water-repellent.htm>

See web link to *Preservation Brief 2 Repointing Mortar Joints in Historic Masonry Buildings*:

<http://www.nps.gov/tps/how-to-preserve/briefs/2-repoint-mortar-joints.htm>

# National Historic Landmark District design guidelines



*This downspout helps to provide proper drainage to minimize rot along the roof eaves and wood columns. It will also minimize issues at the foundation if the downspout directs water away at the ground level.*

## Wood

Wood was used historically for exterior siding, trim, roofing and ornamental details. Early woodwork should be retained, and, if necessary repaired. When properly maintained, wood has a long lifespan. These guidelines apply in addition to the more general materials and finishes guidelines section.

### 1.15 Protect wood features from deterioration.

- Provide proper drainage and ventilation to minimize rot.
- Maintain protective coatings, such as paint, to retard drying and ultraviolet damage.

### 1.16 Match an original wood material in composition, scale, profile and finish if replacement is required.

- For example, if the original material is wood clapboard, then the replacement material should be wood as well. It should match the original in size and the amount of exposed lap, profile and in finish.
- Replace only the amount required. If a few boards or shingles are damaged beyond repair, then only they should be replaced, not the entire wall or roof.

# National Historic Landmark District design guidelines

## Windows

The character-defining features of a historic window, its distinct materials and its location should be preserved. Historic windows can be repaired. Repair and weatherstripping or insulation of the original elements is more energy-efficient, and less expensive than a replacement. Any new windows should be in character with the historic building.

**1.17 Preserve the functional and decorative features of a historic window.**

- Features important to the character of a window include its frame, sash, muntins, mullions, glazing, sills, heads, jambs, moldings, operation and groupings of windows.
- Repair frames and sashes rather than replacing them, whenever possible.

**1.18 Preserve the position, number and arrangement of historic windows in a building wall.**

- On primary facades, enclosing a historic window opening is inappropriate, as is adding a new window opening.
- A new window opening may be allowed on a secondary facade if it is not visible from the public right-of-way and does not damage any key character-defining features. It should also remain subordinate to other windows on the facade.

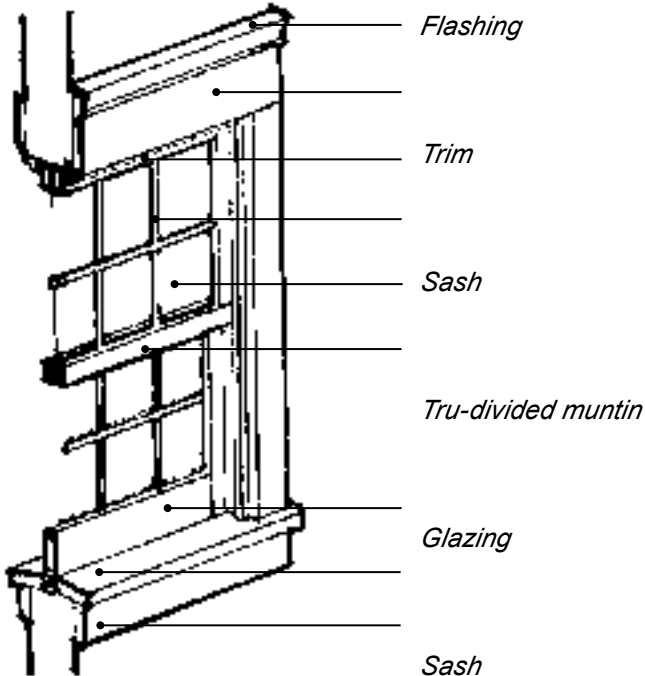

*Features important to the character of a window include its frame, sash, muntins, mullions, glazing, sills, heads, jambs, moldings, operation and groupings of windows.*



*Preserve the functional and decorative features of a historic window.*

# National Historic Landmark District design guidelines



## 1.19 Preserve the historic ratio of window openings to solid wall on a primary facade.

- Significantly increasing the amount of glass on a character-defining facade will negatively affect the integrity of the structure.

## 1.20 Preserve the size and proportion of a historic window opening.

- Reducing an original opening to accommodate a smaller window or increasing it to receive a larger window is inappropriate.

## 1.21 Match the design of a replacement window to the original.

- If the original is double-hung, then the replacement window should also be double-hung or appear to be so. Match the replacement also in the number and position of glass panes.

## 1.22 Use materials that are similar to the original when replacing a window.

- Using the same material as the original is preferred, especially on character-defining facades.
- New glazing should convey the visual appearance of historic glazing. It should be clear. Transparent low-e type glass is appropriate. Metallic and reflective finishes are inappropriate.
- A substitute material may be considered if the appearance of the window components will match those of the original in dimension, profile and finish and it is located on a secondary facade and is not visible from the public right-of-way.
- Vinyl and unfinished metals are inappropriate window materials.

# National Historic Landmark District design guidelines

**1.23 Match, as closely as possible, the profile of a window and its components to that of the original window.**

- The appearance of the window components should match those of the original in dimension, profile and finish.
- A historic wood window usually has a complex profile. Within the window's casing, the sash steps back to the plane of the glazing (glass) in several increments. These are important details that help distinguish the actual window from the surrounding plane of the wall.

**1.24 Convey as closely as possible the character of historic sash divisions in a new window.**

- Muntins that divide a window into smaller panes of glass should be genuine on key facades and other highly visible places.
- Strips of material located between panes of glass to simulate muntins are inappropriate.

## Energy Conservation in Windows

Historic windows can be repaired by reglazing and also patching and splicing wood elements such as the muntins, frame, sill and casing. Older windows were built with well seasoned wood that is superior to most new material. Repair and weatherstripping or insulation of the original elements is more energy efficient, less expensive, and sound preservation practice.

**1.25 Enhance the energy efficiency of an existing historic window, rather than replace it.**

Use these measures:

- Add weather stripping and caulking around the window frame.
- Install a storm window (preferably on the inside.)
- Install an insulated window shade.

### For More Information:

See web link to window retrofit article from the National Trust for Historic Preservation web site:

<http://www.preservationnation.org/who-we-are/press-center/press-releases/2012/new-windows-study.html#.UdshFXFsikl>

# National Historic Landmark District design guidelines



*Preserve the decorative and functional features of a primary entrance.*



*Maintain the original proportions of a historically significant door.*

## Doors

The character-defining features of a historic door and its distinct materials and placement should be preserved. When a new door is needed, it should be in character with the building. This is especially important on primary facades and all walls of the historic adobes.

### 1.26 Preserve the decorative and functional features of a primary entrance.

- These include the door, door frame, screen door, threshold, landing, glass panes, paneling, hardware, detailing, transoms and flanking sidelights.
- Avoid changing the position of an original front door.
- Altering any original door on an adobe is inappropriate.

### 1.27 Maintain the original proportions of a historically significant door.

- Altering the original size and shape of a historic door is inappropriate.

### 1.28 When a historic door is damaged, repair it and maintain its historic appearance.



# National Historic Landmark District design guidelines

## 1.29 Preserve the position of a door on the building wall.

- On primary facades, enclosing a historic door opening is inappropriate, as is adding a new door opening.
- A new door opening may be allowed on a secondary facade if it is not visible from the public right-of-way and is subordinate in character. This is an inappropriate action on an historic adobe.

## 1.30 Preserve the original landing of a primary entrance.

- Avoid changing the position and size of an original landing.
- Preserve landing materials, such as decorative tiles or masonry.

## 1.31 When replacing a door, use a design that has an appearance similar to the original door, or a door associated with the building style or type.

- If the original is a half glass door, then the replacement should also be half-glass.
- Match the replacement dimensionally including the glazing, rails, stiles and panels.



*When replacing a door, use a design that has an appearance similar to the original door, or a door associated with the building style or type.*



*Preserve the original landing of a primary entrance.*

# National Historic Landmark District design guidelines



*Using the historic color scheme is encouraged.*

## Paint/Color

Historically, most wood surfaces on the exterior of a building were painted. Historic adobe structures usually had surface coatings such as mud plaster, lime plaster, and whitewash, so paint should be avoided. These traditions should be continued.

### 1.32 Plan repainting carefully.

- Always prepare a good substrate. Prior to painting, remove damaged or deteriorated paint only to the next intact layer, using the gentlest means possible.
- Use a paint that will be compatible with the historic material. Avoid the use of elastomeric paints on adobe surfaces.

### 1.33 Using the historic color scheme is encouraged.

- Generally, one muted color is used as a background, which unifies the composition.
- For later building styles, such as Queen Anne or Bungalows, one or two other colors may be used for accent to highlight details and trim. These should be applied consistently; for example, do not paint windows a different color.
- Brilliant luminescent and day-glow colors are inappropriate.
- High gloss paints and finishes are inappropriate.

# National Historic Landmark District design guidelines

## Roof

The character of a historic roof should be preserved, including its form and materials, whenever feasible.

### 1.34 Preserve the original roof form of a historic structure.

- Avoid altering the angle of a historic roof. Instead, maintain the perceived line and orientation of the roof as seen from the street.

### 1.35 Preserve the original eave depth of a roof.

- The shadows created by traditional overhangs contribute to one's perception of the building's historic scale and therefore, these overhangs should be preserved. Cutting back roof rafters and soffits or in other ways altering the traditional roof overhang is inappropriate.

### 1.36 Preserve original roof materials.

- Avoid removing historic roofing material that is in good condition.
- Also preserve decorative and functional elements, including chimneys, gutters and downspouts.

### 1.37 When a portion of the roof is damaged, repair it and maintain its general appearance.

- Replace only these areas beyond repair, and do so using material that matches the original.
- For example, on a tile roof, match the shape, color and finish of the original.



*Preserve the original roof form of a historic structure.*



*Preserve original roof materials.*

# National Historic Landmark District design guidelines



## For More Information:

See web link to *Preservation Brief 30 The Preservation and Repair of Historic Clay Tile Roofs*.

<http://www.nps.gov/tps/how-to-preserve/briefs/30-clay-tile-roofs.htm>

### 1.38 New roof materials should convey a scale and texture similar to those used traditionally.

- A roof replacement material should complement the architectural style of the structure.
- A replacement material should have a color, profile, and texture similar to the original.

### 1.39 Apply and detail metal roof materials in a manner that is compatible with the historic character.

- A metal roof material should have a matte, non-reflective finish.
- Seams should be of a low profile.
- The edges of the roofing material should be finished similar to those seen historically.

### 1.40 Avoid using conjectural design features on a roof.

- Adding a widow's walk (an ornate railing around the roof ridge) on a building where there is no evidence one existed creates a false impression of the building's original appearance, and is inappropriate.

### 1.41 Minimize the visual impacts of rooftop devices.

- Locate electronic data transmission and receiving devices to minimize impacts to the extent feasible.

# National Historic Landmark District design guidelines

## Foundation

The foundation of an older building usually consists of the footing, and a concrete or masonry foundation wall that extends up from it. The foundation is mostly below grade. Foundation materials vary; they may be concrete, rough or finished stone, or brick. Historic foundations should be preserved.

### 1.42 Maintain a foundation in good condition.

- Provide positive drainage away from the foundation to minimize accumulation of moisture along the wall.
- Remove sources that cause deterioration, such as water from sprinklers and landscaping.
- When repairing a foundation, use the same kind of material as the original when feasible.

### 1.43 Preserve an original building foundation.

- Avoid removing historic material that is in good condition.
- Removing damaged material that can be repaired is inappropriate.

**1.44 If replacing a portion of the foundation is necessary, it should be similar in character, design, scale and materials to those seen traditionally.**



## Porches, Verandas and Balconies

Porches, verandas and balconies are some of the most important character-defining features of facades in the NHL. They provide visual interest and influence perceived scale. Preserve porches, verandas and balconies in their original condition and form. Repair deteriorated features instead of removing or replacing them. If necessary, replace a missing feature with one that appears similar to that seen historically.

### 1.45 Maintain an original porch, veranda or balcony when feasible.

- Maintain the existing location, shape, details, decking, ceiling, balustrades and posts.
- Missing or deteriorated decorative elements should be replaced to match existing elements; e.g., match the original proportions and spacing of balusters when replacing missing ones.
- Avoid using a building component that is substantially smaller or larger than that seen historically.
- Enclosing a historically significant porch or veranda is inappropriate.

# National Historic Landmark District design guidelines



**1.46 Repair those elements of a porch, veranda or balcony that are deteriorated.**

- Removing damaged materials that can be repaired is inappropriate.

**1.47 If a porch, veranda or balcony has been altered, consider restoring it back to its original design.**

- If the historic design is unknown, then base the design of the restoration on other traditional features on buildings of a similar architectural style.



*Maintain an original porch, veranda or balcony.*

**1.48 When replacing a porch, veranda or balcony is necessary, it should be similar in character, design, scale and materials to those seen traditionally.**

- The size of a feature should relate to the overall scale of the primary structure to which it is attached.
- Base the replacement design on historic documentation if available.
- Where no evidence of the historic feature exists, a new one may be considered that is similar in character to those found on comparable buildings.
- Also see the styles section in the Introduction to identify key features of specific building types.



*If a porch, veranda or balcony has been altered, consider restoring it back to its original design.*

## For More Information:

See web link to Preservation Brief, 45 Preserving Historic Wood Porches:

<http://www.nps.gov/tps/how-to-preserve/briefs/45-wooden-porches.htm>

# National Historic Landmark District design guidelines

## Additions and Secondary Structures

Some older building additions and secondary structures may have taken on historic significance and help to convey the history and evolution of a property. These features should be preserved when feasible. The decision to do so will include consideration of the significance of the primary structure to which such later alterations are a part. In some cases, these changes will help to convey an important period in the property's history. In other situations, however, the primary structure may derive its significance more directly from a period prior to such alterations, in which case removing the alteration may be preferred.

### 1.49 Preserve an older addition that has achieved historic significance.

- Preserve its existing location, form, and materials.
- For example, a porch or bedroom addition that dates from early in the building's history may have taken on significance. Such an addition can often be identified since it is usually similar in character and uses similar building materials.

### 1.50 A more recent alteration that has not taken on historic significance should be removed when feasible.

- For example, an expansion may have occurred that has not achieved historic significance. In this case, the removal of the addition would not have an adverse effect if the purpose was to restore the building.

### 1.51 Design a new addition to be compatible with the main structure.

- An addition should relate to the historic building in mass, scale, character, and form. It also should be subordinate to the primary building.
- Design an addition to be recognized as a product of its own time.
- The roof form of an addition should be similar to the main roof structure.
- An addition to the front of a building is inappropriate.
- More design flexibility may be considered on less visible facades.

### 1.52 Do not damage or obscure architecturally important features with an addition.

- For example, avoid altering a historic cornice line.



*When evaluating the significance of an early alteration, the significance of the primary structure is a key consideration. In some cases, restoring the original condition may be merited, as is the case for this property.*

# National Historic Landmark District design guidelines

## Historic Landscapes and Site Improvements

A variety of landscape designs and features exist in the Old Town NHLD, both formal and informal in character. These include specimen plantings, fences, garden walls, retaining walls, and paving materials. Where historic site features occur they should be preserved. In addition, new features should be compatible with the historic context. New site work that alters the historic context should be avoided.

### 1.53 Preserve historically significant landscapes.

- Maintain the design of historic landscapes including the size, placement and orientation of walks, planting beds and topography, for example.



*Preserve stone curbs, brick walks and other historic paving materials. These unique pavers, made of whale bone are examples.*



*Preserve historic site features, including fences and walls.*



### 1.54 Preserve historic site features.

- Preserve stone curbs, brick walks and other historic paving materials.
- Preserve original fences, site walls and retaining walls.
- Preserve specimen trees and other significant plantings when practicable.

### 1.55 Design new landscapes to be compatible with historic sites.

- A new landscape feature should be subordinate to the historic property.
- Do not install plants near the foundation which could cause water to be introduced into the foundation itself.



*Design new landscapes to be compatible with historic sites.*



#### For More Information:

See web link to *Preservation Brief 36 Protecting Cultural Landscapes: Planning, Treatment and Management of Historic Landscapes*:

<http://www.nps.gov/tps/how-to-preserve/briefs/36-cultural-landscapes.htm>



# National Historic Landmark District design guidelines

## Adaptive Reuse

The best use of a historic structure is that for which it was designed or one that is closely related to it. Every effort should be made to provide a compatible use for the building, one that will require minimal alteration to the building and its site. An example of an appropriate adaptive use is converting a residence into a Bed and Breakfast. This can be accomplished without major alteration of the original architecture.

### **1.56 Seek uses that are compatible with the historic character of the building.**

- The use should not adversely affect the historic integrity of the building.
- The use should not alter character-defining features of the structure.

### **1.57 A new use that requires minimal change to the existing structure is preferred.**

- When a more significant change in use is necessary to keep the building in active service, a use that requires the least alteration to significant features is preferred.
- It may be that in order to adapt a building to a proposed new use, a radical alteration to its significant elements would be required that the entire concept would be inappropriate. In most cases, however, a design can be developed that respects the historic integrity of the building while also accommodating a new function.

# National Historic Landmark District design guidelines

## Miscellaneous Guidelines for both Historic and Non-Historic Properties

These topics apply to all properties in the Old Town NHLD, including contributors, non-contributors and new construction.

### Public Art

Public art is welcomed as an amenity. It should be designed as an integral component of the urban environment and should be strategically located to serve as accent to a streetscape, plaza, park or other public area and should not impede one's ability to interpret the historic character of the area.

#### 1.58 The use of public art that is compatible with the historic context is encouraged.

- Incorporate art that complements the context and character of the district.
- Strategically place public art at civic facilities to serve as accents.
- Public art that helps to interpret the history of the district is especially appropriate.

#### 1.59 Public art should be compatible with the historic context.

- An art installation should not impede one's ability to interpret the historic character of the district or nearby historic structure.
- Locate public art such that the ability to perceive the character of historic buildings nearby is maintained. Placing a large sculpture in front of a historic building entry, for example, is inappropriate.

#### 1.60 Locate public art installations to enhance the urban environment.

- Locate artwork in a strategic location such as a gateway or as a focal point in a public plaza or park.



*Locate artwork in a strategic location such as a gateway or as a focal point in a public plaza or park.*

# National Historic Landmark District design guidelines



*Minimize the visual impacts of building equipment on the public way and the district.*

## Building Equipment

Junction boxes, external fire connections, telecommunication devices, cables, conduits, satellite dishes, HVAC equipment and roof fans may affect the character of a property. Minimize the visual impact of these and similar equipment devices on historic properties.

### 1.61 Minimize the visual impacts of building equipment on the public way and the surrounding neighborhood.

- Screen equipment from view or design it to be visually unobtrusive. For example, use low-profile or recessed mechanical units on rooftops.
- Do not locate equipment on a primary facade.
- Locate telecommunication dishes and mechanical equipment out of public view when feasible.

### 1.62 Minimize the visual impacts of utility lines, junction boxes and similar equipment.

- Locate utility lines and junction boxes on secondary and tertiary walls, and group them, when feasible.
- Consolidate utility lines in conduit, when feasible.
- Paint these elements, to match the existing background color, when feasible.
- Locate utility pedestals (ground mounted) to the rear of the building when feasible.



*Screen a service area with a wall, fence or planting, in a manner that is in character with the context.*

## Service Areas

Service areas should be visually unobtrusive and should be integrated with the design of the site and the building.

### 1.63 Minimize the visual impacts of service areas.

- Orient the entrance toward a service lane and away from major streets.
- Screen a service area with a wall, fence or planting, in a manner that is in character with the context.

# National Historic Landmark District design guidelines

## Security Devices

Historic precedent exists for using shutters and sometimes security bars on openings for security. These were simple and yet decorative in design. Installing a new security device may be considered, but it should be visually unobtrusive and should be integrated with the design of the site and the building.

### Provide shutters on a historic building where there is precedent.

- Shutters may be appropriate for some windows if they were used historically on the building. This can be documented with historic photographs.

### 1.64 Minimize the visual impacts of security devices.

- Exterior metal bars are inappropriate on a historic building except where precedent exists for the specific period and style. If they are to be used, they should have a hand-crafted appearance.

## ATM Automated Teller Machines

An ATM should be visually unobtrusive and should be integrated with the design of the site and the building. An ATM should not be installed where it would alter key features of a historic property.

### 1.65 Minimize the visual impacts of ATM machines within the historic district.

- The preferred sequence of locations for an ATM on a historic building: 1. In a vestibule inside the historic entrance; 2. On a secondary wall, and where it does not alter key character-defining features; 3. In a free-standing structure in a courtyard or rear yard.
- The preferred sequence of locations for an ATM on a non-historic building: 1. In a vestibule inside the entrance; 2. On a secondary wall; 3. In a free-standing structure in a courtyard or rear yard; 4. Incorporated into the composition of a primary facade, however, appearing subordinate to the facade.
- Locating an ATM on the front of a historic building is inappropriate.
- Use a low-profile unit, for example, one that does not project from the wall plane.
- Free-standing enclosures with canopies are inappropriate, unless located at the rear of the property.
- Bold contrasting colors are inappropriate.



*An ATM should be visually unobtrusive and should be integrated with the design of the site and the building.*

# National Historic Landmark District design guidelines

## Site Lighting

Minimizing the light level at a property line is a key design consideration. This is affected by the number of fixtures, their mounting height, the lumens emitted per fixture and color temperature. It is also affected by the screening and design of the fixture. Light spill onto adjacent properties and into the night sky should be minimized. See also G.6.1 and G.6.6.

### **1.66 Shield lighting to prevent off-site glare.**

- Light fixtures should incorporate cut-off shields to direct light downward.
- Luminaires (lamps) shall not be visible from adjacent streets or properties.
- Shield fixtures to minimize light spill onto adjacent properties and into the night sky.

### **1.67 Provide lighting for a pedestrian way that is appropriately scaled to walking.**

- Mount lights for pedestrian ways on low poles or posts.

### **1.68 Light fixtures should be in character with the setting.**

- Fixtures should be compatible with the historic context.

## Building Lighting

The character and level of lighting that is used on a building also is of special concern. Traditionally, exterior lights were simple in character and conveyed a hand-crafted quality. They were used to highlight entrances and signs. Most fixtures were relatively low intensity and often were shielded with simple shade devices. The overall effect of a modest use of building light should be continued.

When installing architectural lighting on a historic building, use existing documentation as a basis for the new design. If no documentation exists, use a fixture that is in character with the building period. Building lighting should be installed in a manner so as not to damage the historic fabric of the building and it should be reversible.

The use of soft lighting to highlight a historic adobe property may also be considered.

### **1.69 Use lighting to accent:**

- Building entrances
- Signs

# National Historic Landmark District design guidelines

*The use of soft lighting to highlight a historic adobe property may also be considered.*



*Fixtures should convey a hand-crafted quality.*



## **1.71 Use shielded and focused light sources to prevent glare.**

- Provide shielded and focused light sources that direct light downward.
- Do not use high intensity light sources or cast light directly upward.
- Shield lighting associated with service areas, parking lots and parking structures.
- Avoid excessive light spill from site fixtures and building fixtures.

## **Decks**

Decks are a contemporary expression of porches, which do not have a historic counterpart; therefore, any deck that is built should be visually subordinate. Generally, there are four types of decks: decks at grade, second story decks, elevated decks (several feet off the ground) and roof decks.

## **1.72 Minimize the appearance of any deck.**

- A deck should not be visible from the public right-of-way in the NHLD.
- Locate a deck to the rear and behind the building.
- A deck design should be subordinate to the building in scale, materials and character.
- Second story decks and roof decks are generally inappropriate in the NHLD.

## **1.70 Minimize the visual impacts of architectural lighting.**

- Use exterior light sources with a low level of luminescence.
- Use lighting fixtures that are appropriate to the building and its surroundings in terms of style, scale and intensity of illumination.

# National Historic Landmark District design guidelines

## Surface Parking

The visual impact of surface parking on the historic character of the NHLHD should be minimized. On-site parking should be subordinate to other uses and the front of any property should not appear to be a parking area.

### 1.73 Minimize the visual impact of surface parking.

- Locate a parking area at the rear, to the side of a site or to the interior of the block whenever possible.
- Do not use the front yard of a property for parking.

### 1.74 Provide a visual buffer where a parking lot abuts a public way.

- This may be a landscaped strip or planter. A combination of trees and shrubs can be used to create a landscape buffer.
- Consider the use of a low or decorative wall as a screen for the edge of the lot. Materials should be compatible with those of nearby buildings.

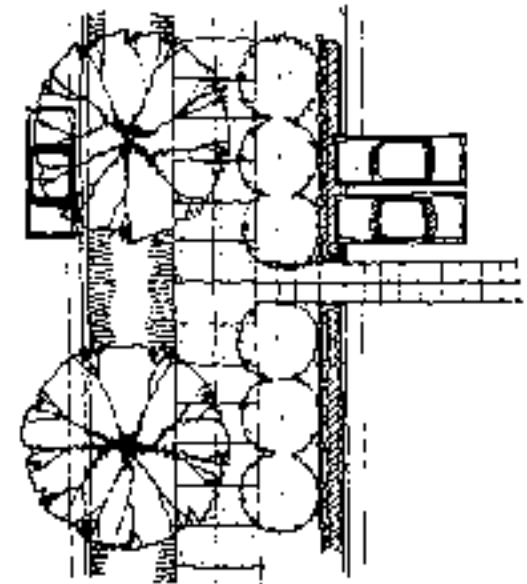

*Provide a visual buffer where a parking lot abuts a public way.*

# National Historic Landmark District design guidelines

## Design Guidelines for New Construction

This section provides general guidance for new buildings (including commercial and residential) within the NHLD. It focuses on the principle of “compatibility,” that is respecting the historic context and deferring to it, in terms of visual impacts, while encouraging new designs that reflect their own time periods. It is especially important to assure that new buildings remain subordinate to the buildings of the Mexican and Early American eras.

### Architectural Character

In order to assure that historic resources are appreciated as authentic contributors to the district, it is important that new buildings be distinguishable from them. Therefore, new construction should appear as a product of its own time, while also being compatible with the historically significant features of the area.

#### **1.75 Design a new building to reflect its time, while respecting key features of its context.**

- Relating to the context is especially important.

#### **1.76 Contemporary interpretations of traditional designs and details may be considered.**

- New designs for window moldings and door surrounds, for example, can provide visual

interest while helping to convey the fact that the building is new.

- Contemporary details for new storefronts also can be used to create interest while expressing a new, compatible style.

#### **1.77 The exact imitation of older historic styles is discouraged for newer structures.**

- This blurs the distinction between old and new buildings and makes it more difficult to visually interpret the architectural evolution of the district.
- An interpretation of a historic style that is authentic to the district may be considered if it is subtly distinguishable as being new.

### Building Orientation

Traditionally, the primary entrance of a building faced the street. In residential settings it may have been sheltered by a porch, veranda or recessed opening; in a commercial setting the entry was often recessed. This orientation should be continued.

#### **1.78 Maintain the traditional orientation of a building to the street.**

- Locate the primary entrance to face the street where it exists.
- Maintain the traditional alignment of buildings along the block.
- Use fences and walls to maintain the streetscape edge, in those contexts where they occur.



# National Historic Landmark District design guidelines

## **1.79 Buildings oriented to a plaza/courtyard should invite pedestrian activity.**

- Orient a building entrance to face the plaza.
- Provide a storefront or pedestrian-friendly facade.

### **Site Design**

When considering the design features of individual building sites, a rich palette appears within the NHLs. Some buildings are located at the sidewalk and others are set back from the street with a moderate yard, shallow yard, or courtyard. A variety of landscape designs and the intermittent use of fences, garden walls and retaining walls are also among those site features that contribute to the character of the districts. These traditional development patterns and site improvements should be continued.

## **1.80 Maintain the traditional alignment of buildings along the block.**

- When constructing a new building, locate it to fit within the range of setbacks along the block.
- Provide a front yard and/or courtyard similar in depth to neighboring properties.

## **1.81 For some contexts, provide a progression of public-to-private spaces when planning a new structure.**

- This can include a sequence of experiences, beginning with the “public” sidewalk, proceeding to a “semi-public” walkway, to a “semi-private” porch, veranda or other entry feature, ending in the “private” space beyond. In some cases, the sequence may proceed directly to a “semi-private” courtyard space.

## **1.82 Site materials shall be similar in scale, color, texture and finish to those seen historically in the context.**

- The use of rock, stucco and wood fences complement certain building styles. Also, consider the context of the building when determining the site materials.

# National Historic Landmark District design guidelines

## Mass and Scale

Traditionally buildings had simple forms, varied heights, articulated masses and pedestrian-scaled front facades. A new building should continue to provide a variety of pedestrian-friendly scales and visually appealing masses. Buildings should not be monolithic in scale or greatly contrast with the existing scale of those seen traditionally in the district.

A sense of human scale is achieved when one can reasonably interpret the size of a building by comparing features of its design to comparable elements in one's experience. Using a building material of a familiar dimension such as traditional wood lap siding is an example. Using building features such as windows, doors, storefronts, verandas and porches that are in scale with those seen traditionally is also encouraged.

These features are some of the important characteristics of buildings types within the district and should appear in new construction. See also S.3.1, G.3.1 and G.3.2.

**1.83 On a larger structure, subdivide the larger mass into smaller “modules” that are similar in size to traditional buildings within the context.**

**1.84 Construct new building features to reflect the mass and scale of traditional buildings.**

- Use building features of traditional dimensions. For example, the use of windows, doors, storefronts, verandas and porch elements in scale to those seen traditionally is appropriate.

**1.85 Express facade components in ways that will help to establish a human scale.**

- Include horizontal elements in the design. For example, use verandas, porches, eaves and groupings of windows to convey human scale.



*On larger structures, subdivide larger masses into smaller “modules” that are similar in size to traditional buildings within the context. Note the similar facade widths in this series of buildings*

# National Historic Landmark District design guidelines

*A new building should reflect the established range of the traditional building widths seen in the district.*



## **1.86 A facade should reflect dimensions similar to traditional buildings in the area.**

- Facade heights of new buildings should respect the traditional proportions of height to width.
- Floor-to-floor heights should appear similar to those of traditional buildings.

## **1.87 Maintain traditional spacing patterns created by the repetition of uniform building widths along the street.**

- A new building should reflect the established range of the traditional building widths seen in the district.
- Where a building must exceed this width, use a change in design features to suggest the traditional building widths. Changes in facade height or wall offsets are examples of techniques that may be used. These variations should be expressed consistently throughout the structure, such that the building appears to be a composition of smaller building modules.

## **Building and Roof Form**

A prominent unifying element in the district is the similarity in building forms that exists. Most are simple rectangular forms. This simplicity of form should continue, in terms of the predominant features of any new building.

### **1.88 A rectangular form should be dominant.**

- The facade should appear as a flat surface. Decorative elements, projecting elements or recesses should appear to be subordinate to the dominant form.

### **1.89 A roof form should be similar to those used traditionally.**

- Flat, gable and hip roofs are appropriate.
- “Exotic” roof forms, such as A-frames and steep shed roofs, are inappropriate.

# National Historic Landmark District design guidelines

## Solid-to-Void

**1.90 Use a ratio of solid-to-void (wall-to-window) that is similar to that found on historic structures within the neighboring context.**

- Large surfaces of glass are inappropriate.



*Use a ratio of solid-to-void (wall-to-window) that is similar to that found on historic structures within the context.*

## Materials

Building materials for new structures and additions to existing buildings should contribute to the visual continuity of the district. They should appear similar in finish to those seen traditionally. See also G.5.11 - G.5.7.

**1.91 Building materials shall be similar in scale, color, texture and finish to those seen historically in the context.**

- Traditional materials, including wood, stone, brick and stucco, are preferred.
- All wood siding should have a weather-protective finish.
- Imitation or synthetic materials, such as aluminum or vinyl siding, imitation brick or imitation stone and plastic, are inappropriate.
- The use of highly reflective materials is discouraged.

**1.92 Use masonry that appears similar in character to that seen historically.**

- For example, brick and stone should have a dimensions similar to those used traditionally.

# National Historic Landmark District design guidelines

**1.93 New materials that are similar in character to traditional ones may be acceptable with appropriate detailing.**

- Alternative materials should appear similar in scale, proportion, texture and finish to those used traditionally.

**1.94 Use high quality durable materials.**

- The material should maintain an intended finish over time, or acquire a patina, which is understood to be a likely outcome.
- Materials at the ground level should withstand ongoing contact with the public, sustaining impacts without compromising the appearance.

**1.95 Use architectural ornamentation with restraint.**

- While some examples of ornamentation occurred traditionally, these were generally modest in scale, number and character.
- Highly ornate, formal details are inappropriate.

## New Secondary Structures

**1.96 Locate a new secondary structure in a traditional location on the lot.**

- For example, these structures were often located at the rear of the lot.

**1.97 A new secondary structure should be similar in character to those seen traditionally.**

- Use simple rectangular forms with hip, flat or gable roofs.
- Contemporary interpretations of traditional secondary structures should be permitted when they are compatible with the primary building on site.

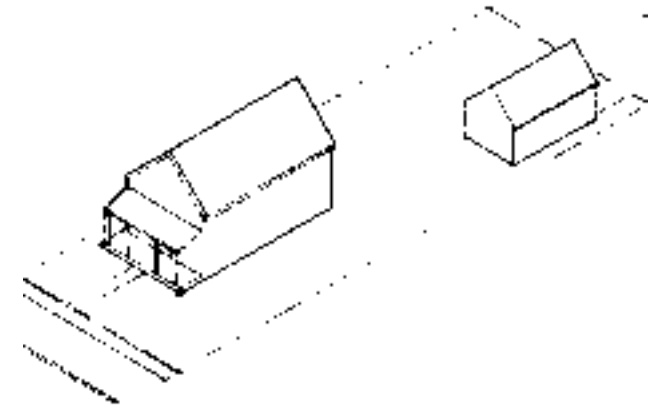

*Locate a new secondary structure in a traditional location on the lot.*

This page left intentionally blank

# 07 circulation, parking & streetscape

This page left intentionally blank



# circulation, parking, & streetscape

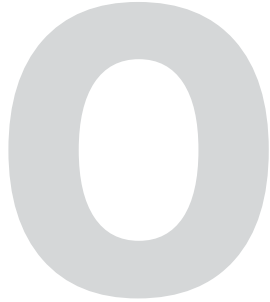

## Circulation, Parking, & Streetscape

Downtown Monterey is frequently described as a confusing maze of streets. The vision of the General Plan Circulation Element is that Monterey will be a City where alternative forms of transportation are so attractive that the use of an automobile is a choice, not a necessity. The transportation system will be safe for all users and support the local economy while maintaining the historic character of the City.

During the planning process, the City established the following goal to specifically address transportation issues in Downtown Monterey:

*“Create a seamless transportation network that integrates the Downtown network with the surrounding area. Eliminate the confusing street names and complicated downtown network of one-way streets while providing for easy pass-through from west to east, and ease of access for bicycles. Develop and implement a pedestrian, transit (mass, trolley and shuttle), and bicycle friendly environment which will encourage people to get out of their cars and walk the Downtown after parking in parking structures around the periphery of the Downtown. Create a continuous pedestrian/transit concourse from Wharf # 1 to Polk Street.”*

This chapter defines a variety of solutions designed to meet the Downtown Specific Plan Goal in terms of each of the following:

- Traffic Circulation
- Transit
- Bicycle Network
- Pedestrian Network
- Streetscape and Plazas
- Wayfinding and Public Signs
- Traffic Signals and Street Lights
- Parking

# circulation, parking, & streetscape

## TRAFFIC CIRCULATION

The Specific Plan includes the following improvements for traffic circulation:

- Street Renaming
- Two-Way Circulation
- Pearl and Polk Redesign
- Calle Principal Roundabouts
- Custom House/Alvarado Street/  
Scott Street Extension

### Street Renaming

Several street names in Monterey change as they travel through the City; this system makes it confusing for drivers to navigate into and out of Downtown. For example, there is minimal signage on southbound Highway 1 directing visitors to the appropriate highway exit to Downtown. While the Fremont Street exit is a main route to downtown, there is currently no indication to visitors that Fremont Street changes its name to Munras Avenue and then to Alvarado Street as one approaches Downtown Monterey. Similarly, the Munras Avenue exit from northbound Highway 1 makes it challenging for visitors to understand the correct way to downtown, as Munras Avenue changes to Abrego Street and then to Washington Street before it intersects with Del Monte Avenue.

While several other options for renaming streets were

considered, the preferred alternative will change Fremont Street and Munras Avenue to Alvarado Street, such that Highway 1 will have an exit to Downtown Monterey signed “Alvarado Street”. Also, Munras Avenue, Abrego Street, and Washington Street will be renamed Abrego Street (Figure 10). The renaming will ensure consistent naming of the primary downtown access routes as they connect to Highway 1, making it clearer to drivers exiting the freeway. This improvement will create a more intuitive path into the Downtown area. A continuous and consistent street naming approach will benefit both visitors and residents.

# circulation, parking, & streetscape

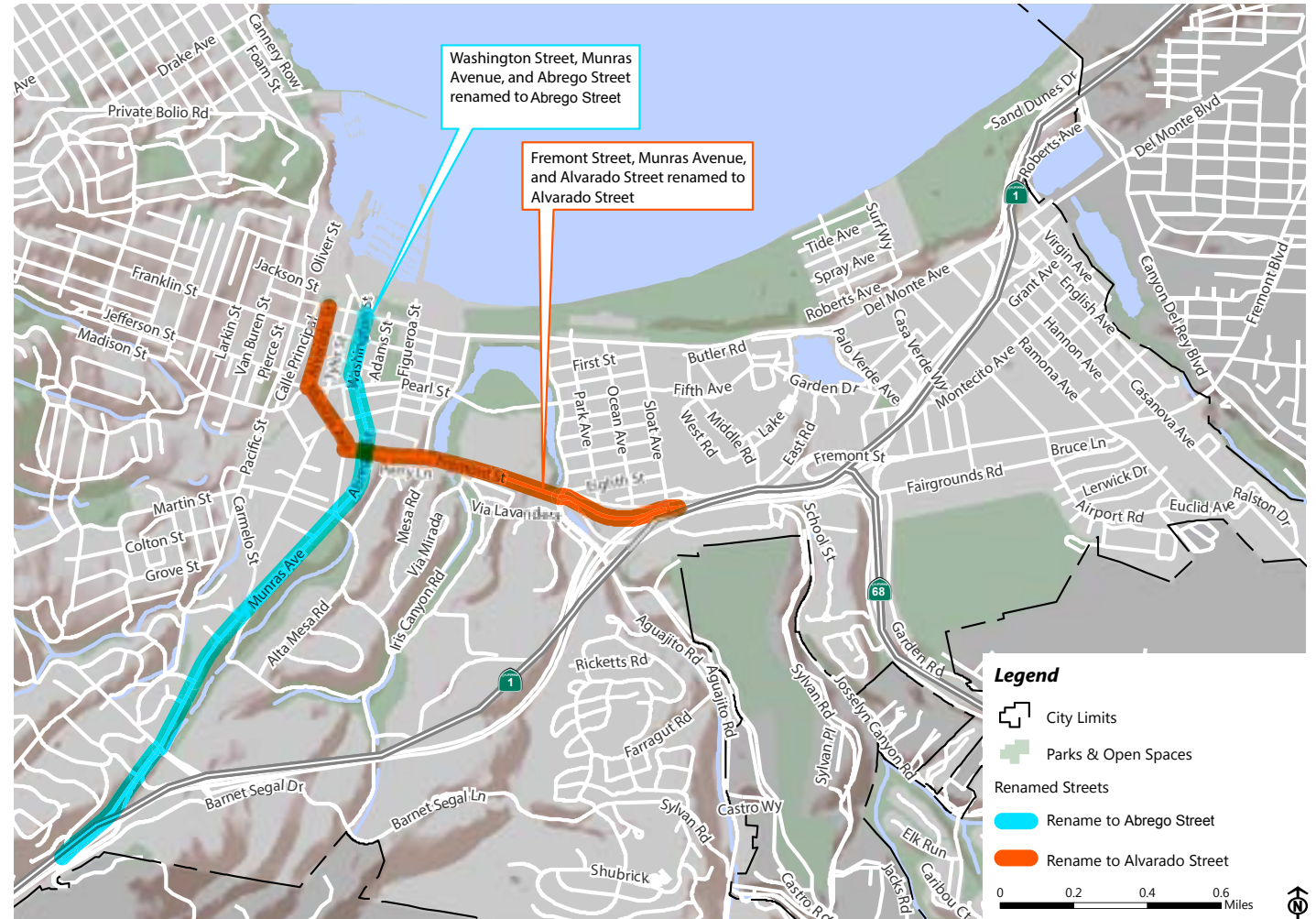

Figure 10: Downtown Street Renaming

# circulation, parking, & streetscape

## Two-Way Street Circulation

In order to create a street network that embraces all travel modes, including automobile, bus, pedestrian and bicycle travel, a two-way circulation street network is planned for Downtown Monterey. This concept converts the following existing one-way street segments to accommodate two-way traffic:

- Alvarado Street from Pearl Street to Del Monte Avenue
- Del Monte Avenue from Washington Street to Pacific Street
- Franklin Street from Pacific Street to Camino El Estero
- Tyler Street from Del Monte Avenue to Franklin Street
- Washington Street from Del Monte Avenue to Franklin Street
- Jefferson Street from Alvarado Street to Calle Principal

Advantages of two-way streets include more direct access to destinations and easier wayfinding for travelers unfamiliar with Downtown Monterey. The conversion from one-way streets to two-way will also result in more direct vehicle routing to parking garages, more efficient bus routing through Downtown and improved accessibility to local shopping and businesses, resulting in less congestion from vehicles circling to find parking and shops. The intent is to design slow, safe two-way streets in Downtown.



# circulation, parking, & streetscape

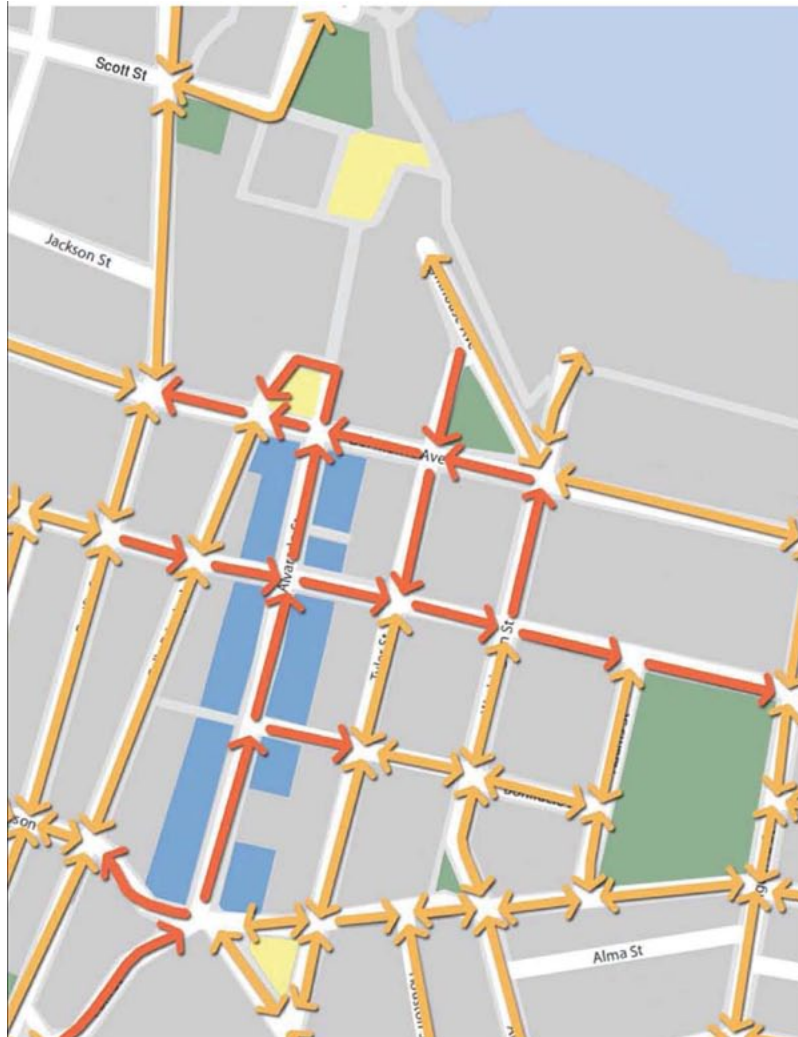

Existing

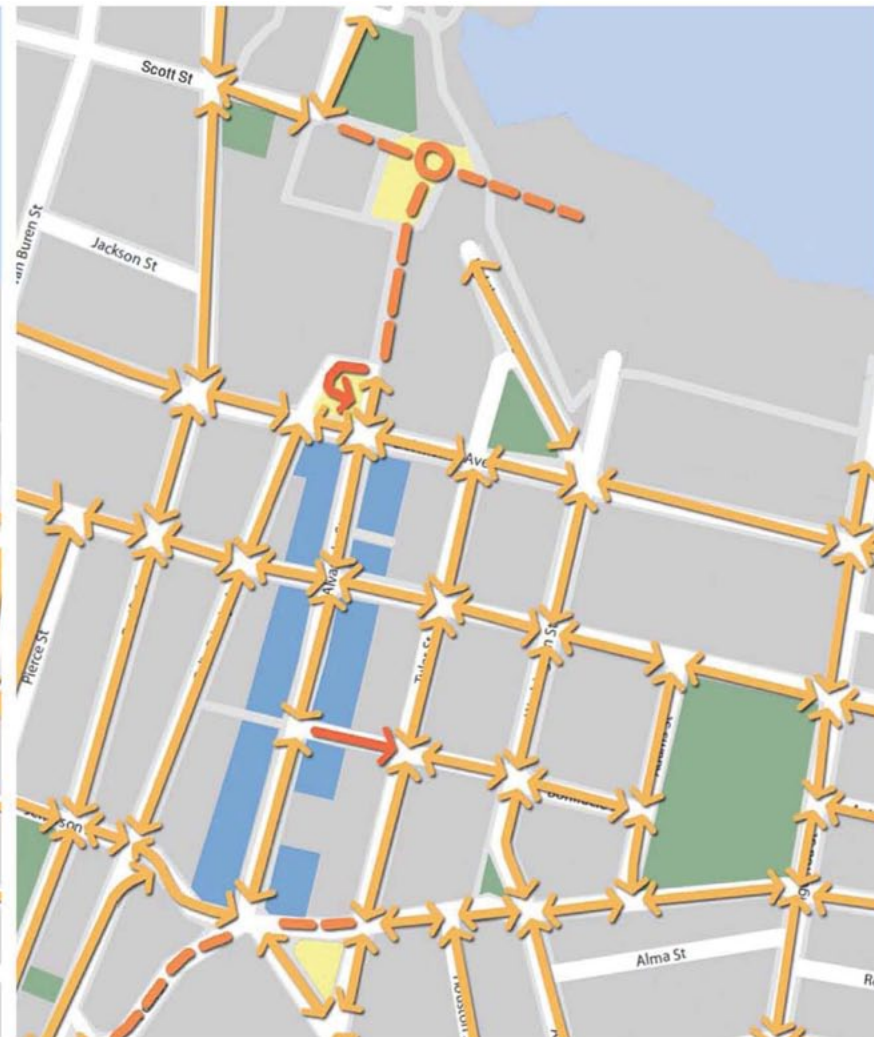

Proposed

## Traffic

One-Way - **Red**

Two-Way - **Yellow**

Limited Access - **Orange**

# circulation, parking, & streetscape



south access - to Alvarado Street



north access - to Alvarado Street



south access - to parking

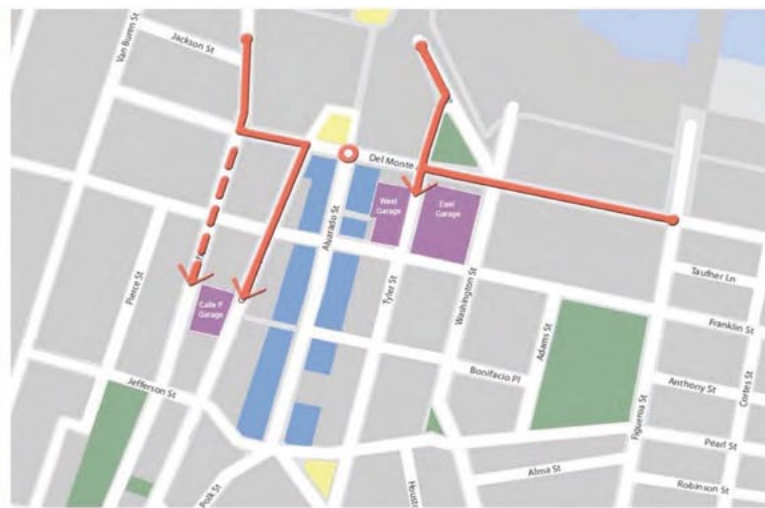

north access - to parking

# circulation, parking, & streetscape

## Pearl and Polk Streets Redesign

The conversion of Alvarado Street to two-way requires the simplification of the five-legged intersection at Pearl Street, Polk Street, Munras Avenue, and Alvarado Street. This is achieved by downgrading Polk Street and the block of Pearl Street between Alvarado Street and Tyler Street.

The block of Pearl Street between Alvarado Street and Tyler Street is proposed as a bicycle boulevard, which would allow bicycles, pedestrians, and emergency vehicles. This change would restrict the use of the existing driveway to access the Ordway Pharmacy parking lot. A near-term option is to create a driveway along Pearl Street into the Ordway Pharmacy. A longer-term option is to demolish the Davi Real Estate building and construct a new surface parking lot accessible from Tyler Street, adding approximately 17 parking spaces to the existing lot (a 60% increase) in a central downtown location. The successful implementation of this alternative requires cooperation between the property owners, either through a joint ownership agreement or land sale. It also creates a new future commercial opportunity site at a key location in the Downtown. Redevelopment of the site would have the opportunity to activate an edge of the plaza with a type of commercial use and activity that maximizes its prime location on the plaza and relocates parking underground.

Polk Street would be downgraded to a “shared street” that highlights the “Island of the Adobes” section of the Downtown, invites pedestrian and bicycle traffic, and showcases the City’s prime collection of historic adobe structures. The design retains a single vehicle travel lane with parking on both sides, adds landscaping, and expands sidewalks. Emergency vehicles would be accommodated, providing direct access to Alvarado/Munras. Polk Street would appear as a driveway that is accessed from Hartnell Street. This design would promote through traffic via Calle Principal and Jefferson Street instead of Polk Street.

# circulation, parking, & streetscape



*Conversion of Polk Street to a pedestrian zone would visually echo the historic nature of the Island of Adobes*



# circulation, parking, & streetscape



*existing Pearl Street*

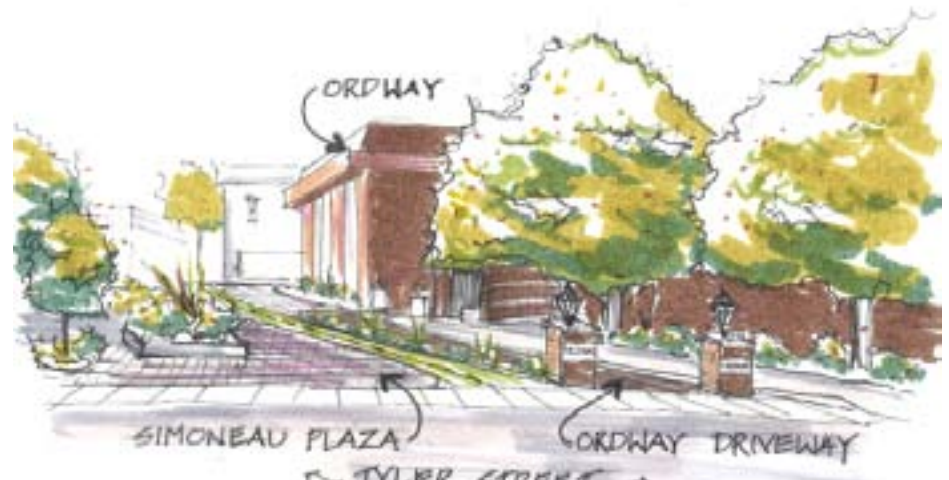

*future Pearl Street driveway access and bike boulevard*

# circulation, parking, & streetscape

## Calle Principal Roundabouts

The replacement of the four-way intersections with roundabouts at Calle Principal and Jefferson Street and Calle Principal/Hartnell/Polk/Madison Streets provide a visual cue for travelers entering the South Historic District. The roundabout at Calle Principal and Jefferson Street solves the queuing issues that result from the conversion of Jefferson Street to two-way circulation. This new three-legged intersection also provides a gateway feature for the historic Larkin House.

A second roundabout at Calle Principal/Hartnell/Polk/Madison Streets reduces vehicular conflicts while also serving as a gateway feature into the new pedestrian-oriented Historic Polk Street. The roundabouts will improve traffic flow at these two locations while creating new unique streetscape features that promote these intersections as the southern entry to downtown.



*Court Square in Montgomery, Alabama was recently redesigned as an historic traffic circle which is one option for how the Calle Principal roundabouts could be designed.*

# circulation, parking, & streetscape

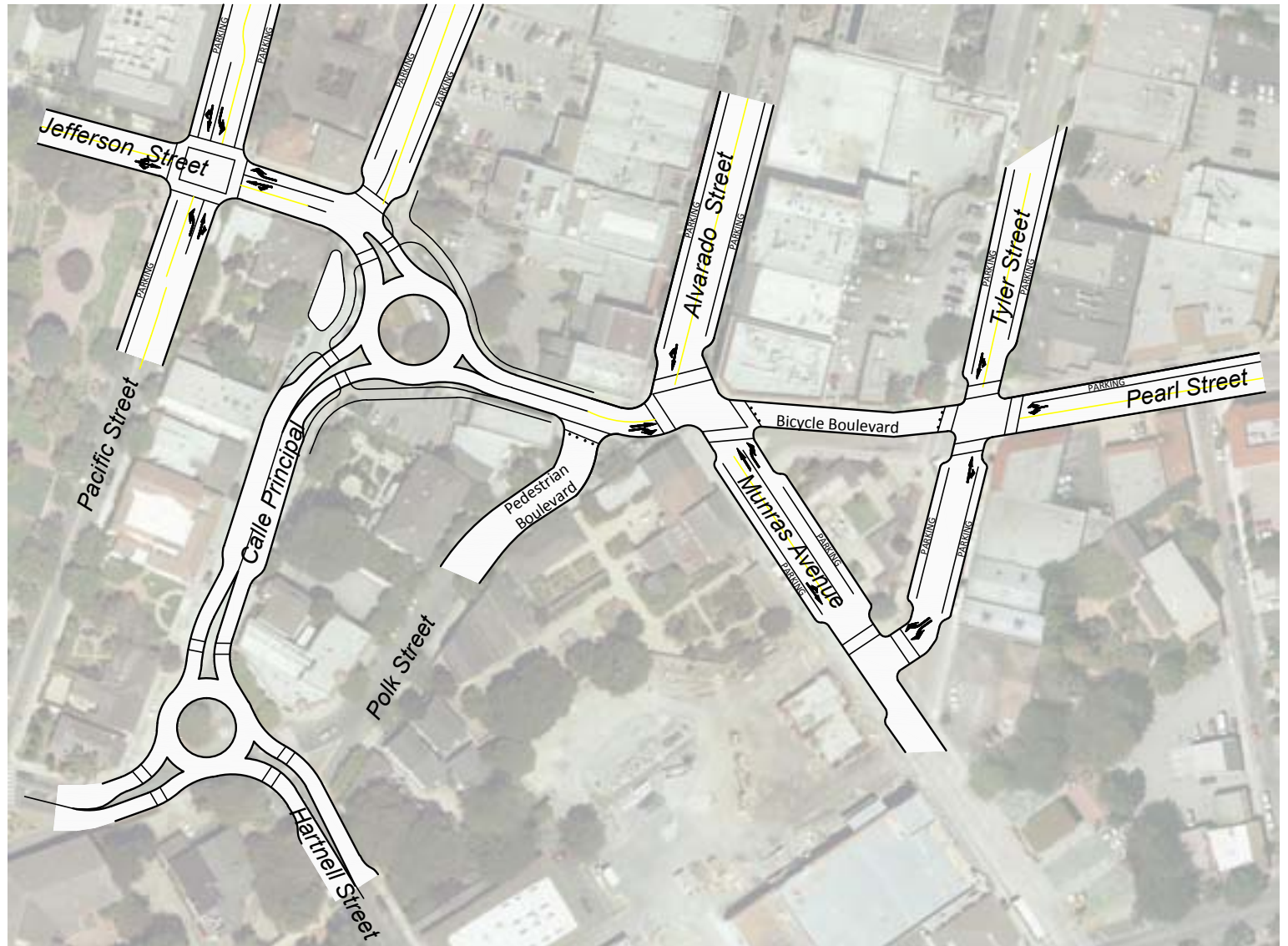

Figure 11: Roundabouts along Calle Principal at Jefferson Street and Madison/Hartnell/Polk Streets

# circulation, parking, & streetscape

## Custom House Plaza / Alvarado Street / Scott Street Extension

Custom House Plaza is a primary gathering area in Downtown but is visually disconnected from businesses and Fisherman's Wharf, resulting in limited pedestrian activity. The solution extends multi-modal access north on Alvarado Street and east on Scott Street to Custom House Plaza to make each street more inviting and encourage pedestrian activity.



# circulation, parking, & streetscape

The extent of vehicle access on the Alvarado and Scott extension will be defined at a later time but the street will be designed to limited vehicle speeds of less than 10 miles per hour. The street extensions could limit vehicle access through the placement of bollards and primarily allow access for transit vehicles, bicycles and pedestrians. The restoration of automobile, bicycle, and transit access will promote Custom House Plaza as a more visible location and a more connected part of the City's street network.



# circulation, parking, & streetscape

## TRANSIT

The MST transit station will be moved from Simoneau Plaza to the Washington Street area, rights-of-way, or alternative area. With its move, the station will be repurposed into a Multi-Modal Center with enhanced public parking, bus service, electrical vehicle recharging stations and bicycle parking. Besides fulfilling the objectives of the Specific Plan, the Multi-Modal Center design will implement the goals and objectives of the Multi-Modal Mobility Plan and the Waterfront Master Plan. Improvements to the Del Monte Avenue/Washington Street intersection will also be a key consideration in this design.



# circulation, parking, & streetscape

## Existing Parking Garage

*Form, color, access and  
lighting must be improved  
at a minimum*



## Multi-Modal Transit Station Concept



# circulation, parking, & streetscape

## BICYCLE NETWORK

Bicycle access to and through the Downtown is challenged by the one-way street network. The City's Multi-Modal Mobility Plan identifies a number of connections designed to improve access and better link the Downtown to other destinations. The most important features include the Bicycle Boulevard that connects the Naval Postgraduate School to the Oak Grove/Old Town/New Monterey neighborhoods through the Downtown and connections between the Downtown and the Waterfront.

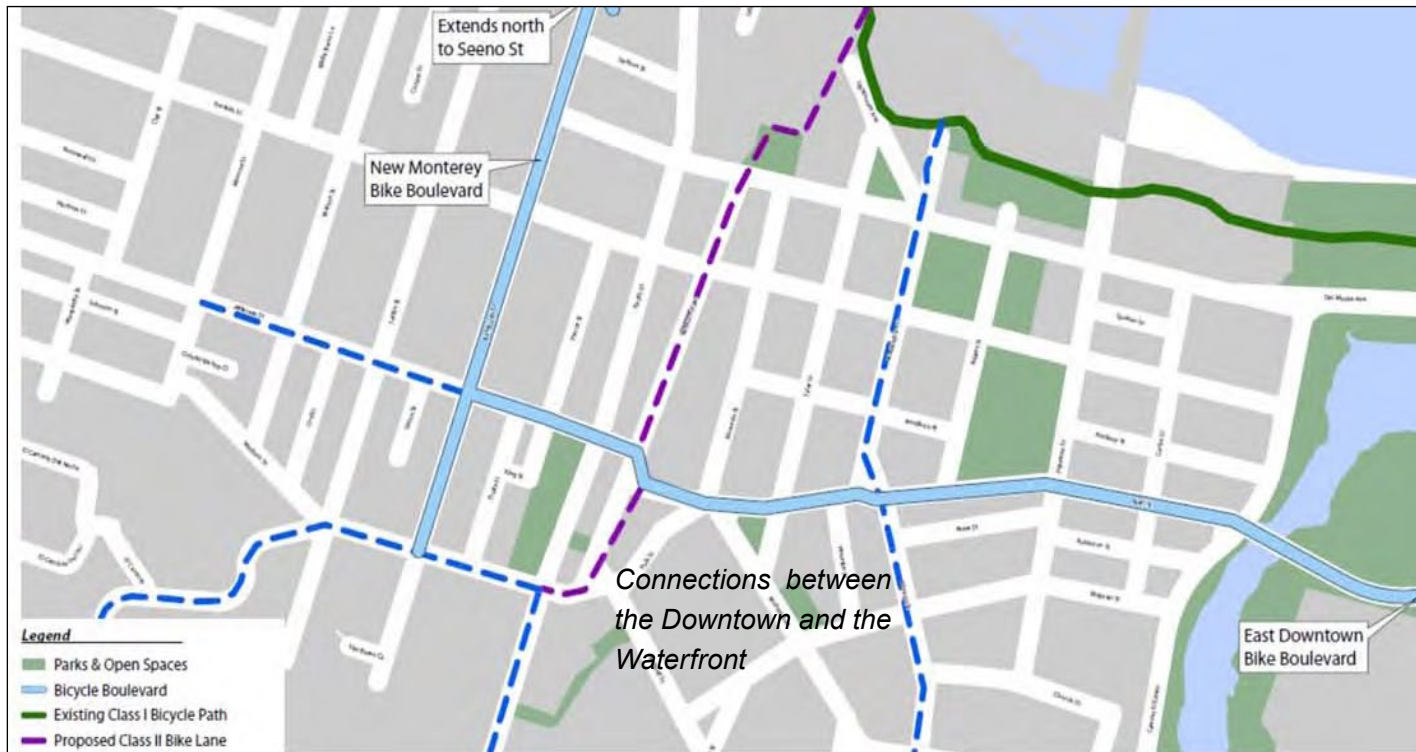



# circulation, parking, & streetscape

## PEDESTRIAN NETWORK

Monterey has the potential to have a thriving and walkable downtown because of its flat terrain, ideal climate, and proximity to exciting destinations. Pedestrian destinations such as the Waterfront, Custom House Plaza, commercial businesses on Alvarado Street, historic buildings on Polk Street, and Simoneau Plaza provide the foundation for a superior walking experience. However, pedestrian activity is currently discouraged because of the poor visual pedestrian connections and wayfinding that would otherwise cue pedestrians to travel between the Waterfront and the Downtown, and the confusing street network, which discourages pedestrian activity from filtering into the Downtown core.

The Specific Plan includes the following improvements to the pedestrian network:

- Improved connections between parking garages and Alvarado Street
- Improved entrances to parking garages
- Path of History
- Themed path of area attractions
- Draws for pedestrian activity

## Areas of Focus & Key Connections

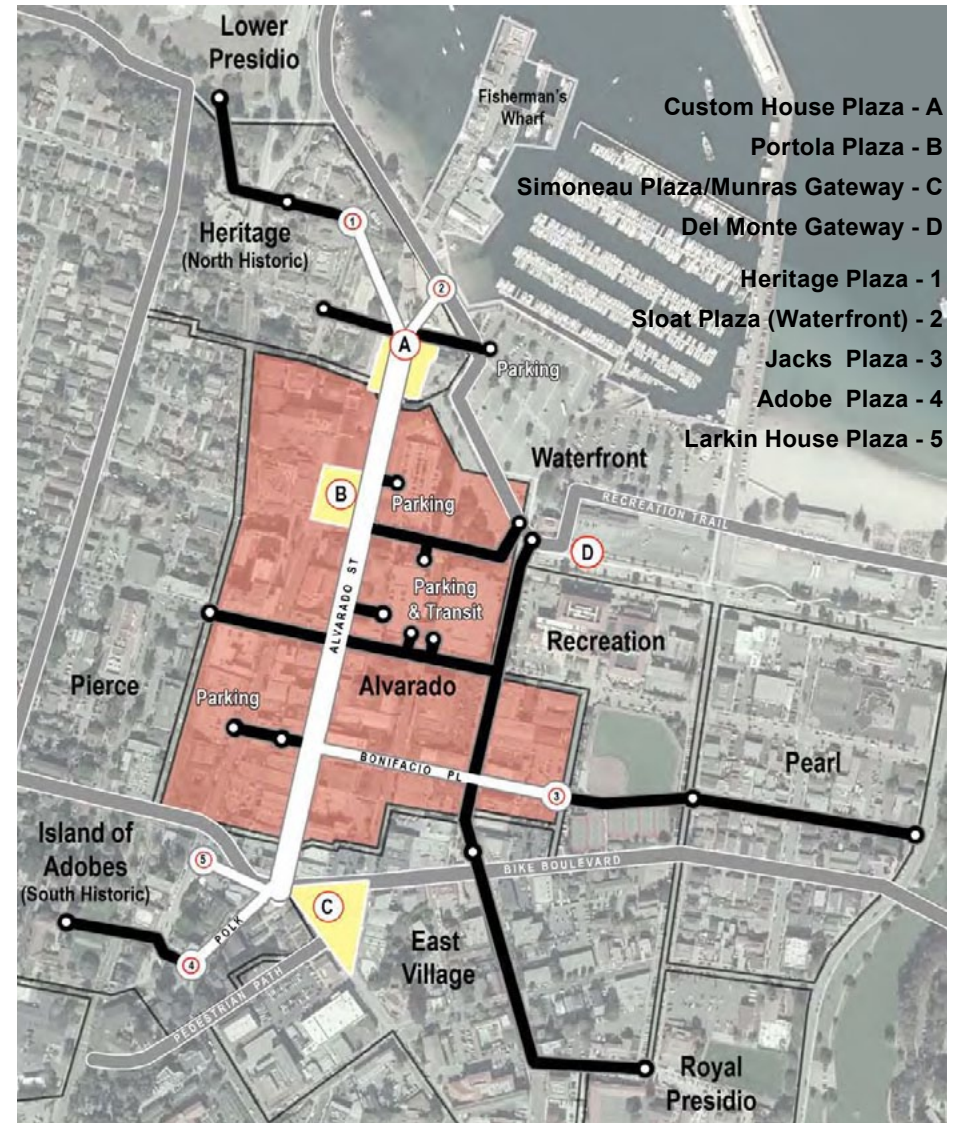

# circulation, parking, & streetscape

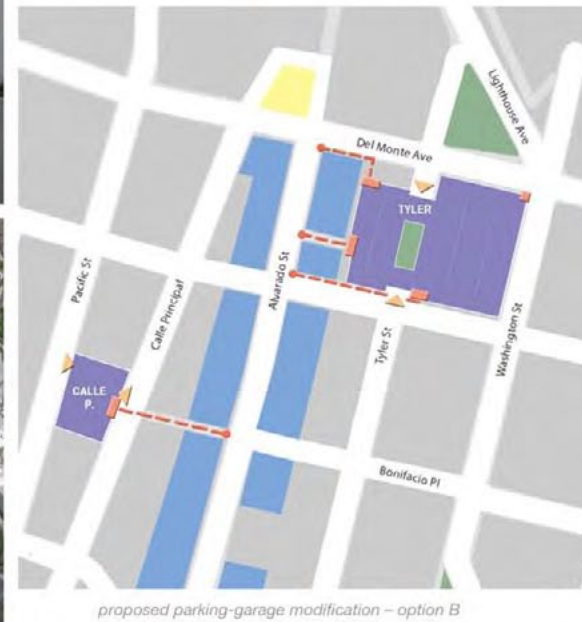
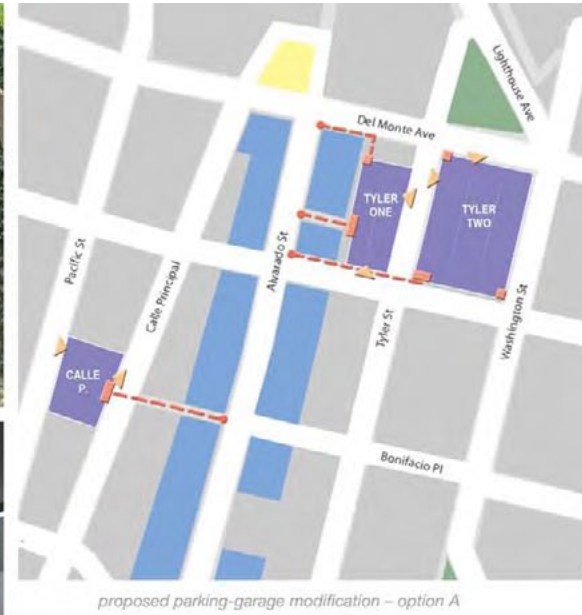

## Connections Between Parking Garages and Alvarado Street

Existing pedestrian connections through the Downtown are physically and visually very poor. Rebuilding pedestrian access points will improve access and safety as shown in adjacent photos and graphics

# circulation, parking, & streetscape

## Entrances to Parking Garages

Pedestrian connections to and from the parking garages should be inviting and memorable. Upgrades could include quality outdoor seating, improved landscaping, decorative lighting, heraldic signs, and umbrellas.



*Existing*



*Possible improvement concept*

# circulation, parking, & streetscape

Entrances to Parking Garages (cont.)



*Existing*



*Possible improvement concept*

# circulation, parking, & streetscape

## Entrances to Parking Garages (cont.)

*Existing*



*Possible improvement  
concept*



# circulation, parking, & streetscape

## Path of History

The existing path, while quite interesting, is too overwhelming for most visitors and novice historians. To see all 40 historic buildings requires a significant amount of time. By offering shorter alternate paths, visitors can see around 20 historic properties, including some of the most significant, in one-third of the time and distance. This shorter adventure should attract more people to the experience. The longer path will continue to be available for the determined adventurer.

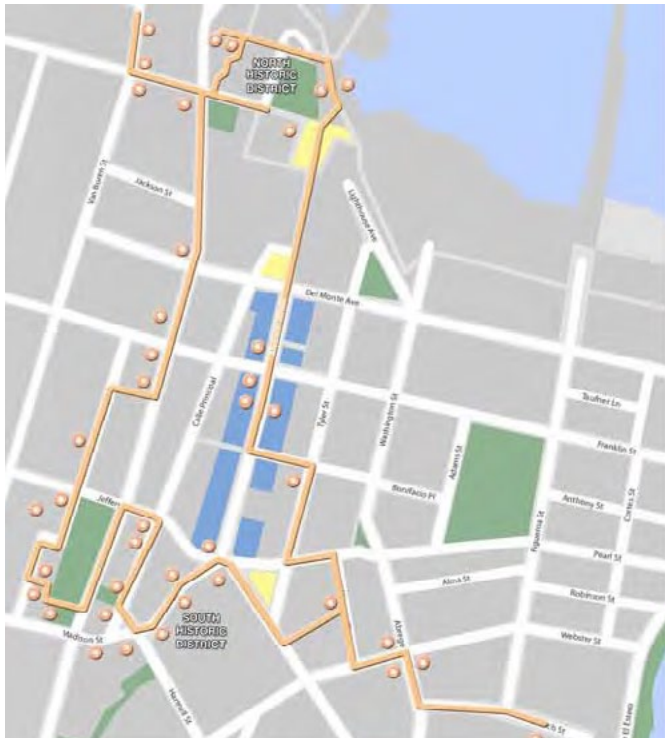

Existing

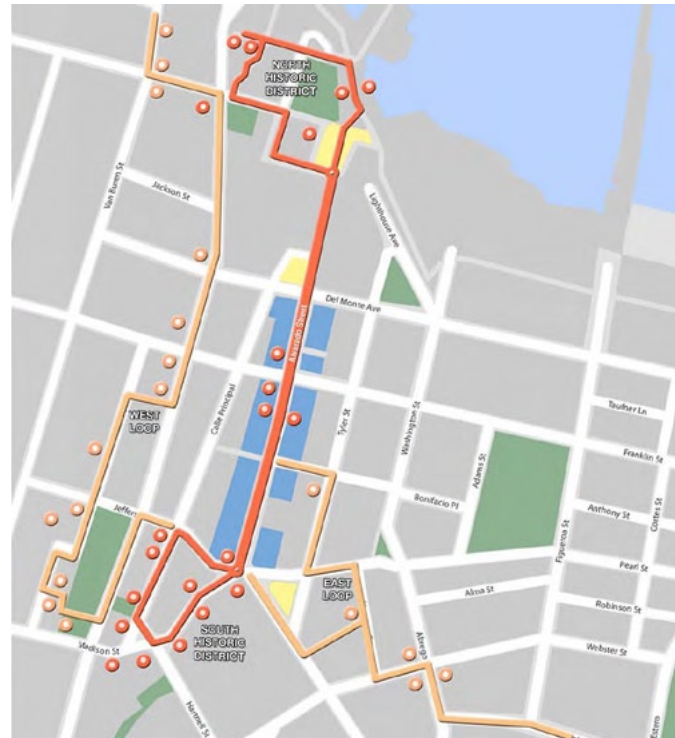

Proposed

# circulation, parking, & streetscape

## Themed Path of Area Attractions

In addition to the retail, attractions, and historic buildings, an additional path could be integrated into the Downtown to express the spirit of Monterey using key regional motifs. The path could connect seven existing or modified plazas with a featured centerpiece. Each plaza and focal centerpiece would highlight an important feature that defines Monterey.

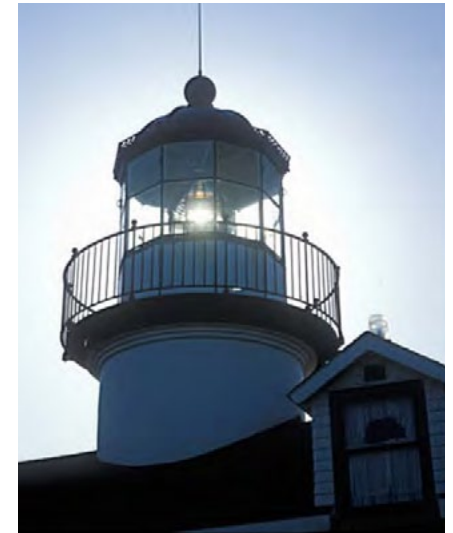

- 1 - Heritage Plaza
- 2 - Sloat Plaza
- 3 - Jack's Plaza
- 4 - Larkin House Plaza
- 5 - Adobe Plaza
- 6 - Simoneau Plaza
- 7 - Portola Plaza

# circulation, parking, & streetscape

## Draws for Pedestrian Activity

The success of the Tuesday Farmers Market indicates that Downtown could support additional street markets and festivals. Potential markets and events could include pet parades, sidewalk chalk art festivals and an antiques and book market.





# circulation, parking, & streetscape

## STREETSCAPE AND PLAZAS

This section will describe proposed improvements to the following:

- sidewalks
- crosswalks and intersections
- street furnishings
- sidewalk seating
- plazas (Portola Plaza, Custom House Plaza, Simoneau Plaza, and connections between the plazas)

### Sidewalks

Alvarado Street sidewalk paving is a significant design feature in Downtown Monterey. The paving texture and color add character to the streetscape. The majority of existing sidewalk pavers should be retained. The replacement of select decorative pavers, as shown in the adjacent photo, will help to energize the Downtown streetscape.

The Specific Plan also proposes that special places such as Bonifacio Place and the proposed bicycle



*Example of decorative pavers in roadbed*



*Inappropriate*



*Appropriate*



*Existing*



*Proposed*

# circulation, parking, & streetscape

boulevard between Tyler and Munras have special paving treatment. All other areas should have concrete sidewalks.

Utility box covers that do not blend with the sidewalk have the potential to ruin an otherwise attractive streetscape. All utility box covers shall be designed to match the adjacent sidewalk or pavement material.

Sidewalk treatment within the National Historic Landmark District will be specified by the National Historic Landmark District Design Guidelines that are currently under development.

## Crosswalks and Intersections

The use of special intersection treatments, such as pavers or stamped concrete for heavily-used pedestrian crossings aid to slow vehicles entering the intersections. Crosswalks within the downtown core shall be sand set pavers with a concrete border as illustrated below. All major intersections along Alvarado Street and Calle Principal will be designed for an all-way pedestrian crossing.



*Proposed crosswalk treatment*



*Example of treatment for all-way pedestrian crossing*

# circulation, parking, & streetscape



*existing street furniture*



*proposed street furniture*



*tree guard*



*bollard*



*tree grate*



*sidewalk seating fence*

## Street Furnishings

Much of the Alvarado Street streetscape, from street furniture to tree grates, is due for an upgrade. Street furnishings provide important amenities for pedestrians by adding functionality and visual detail.

Recommended street furnishings are illustrated to the left and on the following pages and include benches, sidewalk dining areas, bicycle racks, bollards, flower stands, kiosks, news racks, parking meters, public art, sidewalk restrooms, trash/recycling receptacles, lamp posts, bus shelters, information/wayfinding structures, and tree grates and skirts.

Existing trees and other street landscaping should be reevaluated to ensure a consistent level of quality. Street and sidewalk cleaning should be more consistent as well.

## Street Furniture

*Street furniture upgrades will help enhance the character of Alvarado Street.*

## Tree Grates

*Tree grate specifications will require adoption by the City.*

# circulation, parking, & streetscape

## Sidewalk Seating

Sidewalk seating is encouraged in Downtown Monterey. It has traditionally been located directly next to the building.

Another opportunity is to allow outdoor seating to replace on-street parking spaces along Alvarado Street in specified locations.



*Historic Alvarado Rights-of-Way*



*The Alvarado Street right-of-way narrows from south to north along the corridor. As a result, sidewalk widths may vary one to two feet*

# circulation, parking, & streetscape



Sidewalk seating can bring more activity and energy to Alvarado Street. Rebuilding the sidewalks over parking stalls can provide permanent outdoor seating areas.

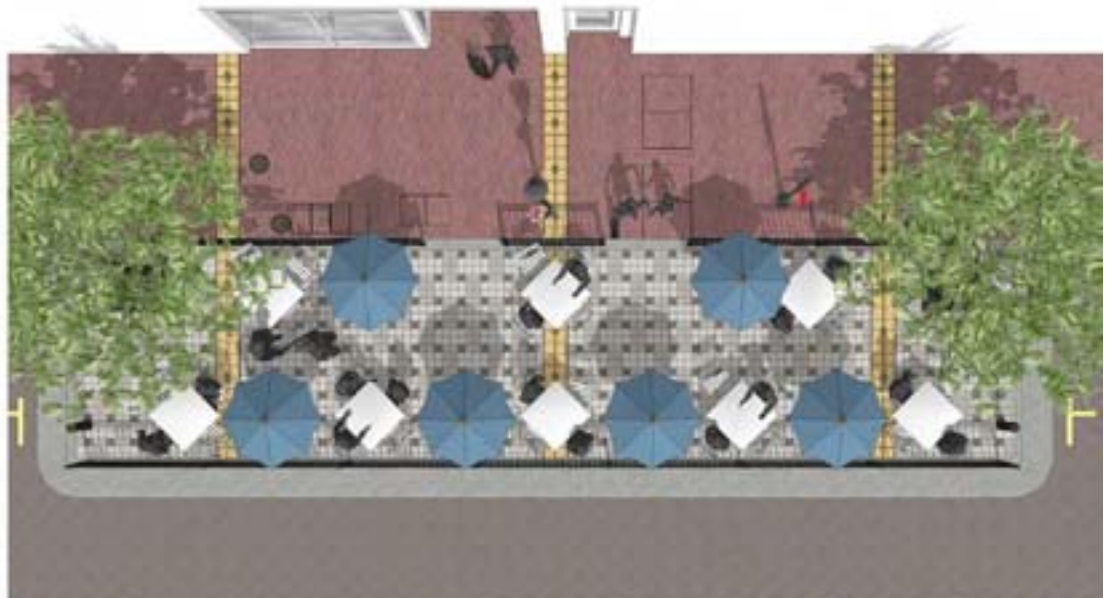

# circulation, parking, & streetscape



*examples for re-energizing Bonafacio Place*

## **Bonafacio Place**

*Bonafacio Place is a unifying street that weaves together various components of the Alvarado District. It could be designed to be traffic-free during dining hours to allow the placement of tables and chairs in a new streetscape.*



# circulation, parking, & streetscape

## Plazas

Monterey's plazas create public spaces that enhance the Downtown experience. Downtown contains three prominent plazas - Portola, Custom House and Simoneau. Each plaza has a unique function - a symbolic center of the City, a large festival/event venue, a critical pedestrian link between the Waterfront and the Downtown, and an intimate setting for local events. The Specific Plan also incorporates artwork to connect the plazas.

### Portola Plaza

Portola Plaza is visually and symbolically the center of Downtown. In many ways it represents the soul of the city. Currently, that soul is perceived as uninviting, tired and uninspiring.

The Portola Plaza should be a "postcard" spot for Monterey - an iconic place that visually identifies and represents the Downtown and the city. As a world-class plaza - a destination for every visitor to Monterey, and a gathering spot for all Downtown customers - it should have a dramatic feature as its centerpiece.

Portola Plaza is the key nexus joining Downtown's primary retail - the Alvarado District - with the Heritage District, including Fisherman's Wharf and the emerging Waterfront. Pedestrian circulation from Alvarado Street should flow smoothly through the plaza to the Alvarado Mall. The current plaza design discourages this flow.

As well as reinforcing Alvarado Street, the Portola Plaza should embrace its outlining facades (north, south, east and west) and the streets and sidewalks between them.

Finally, the Portola Plaza must function as a welcoming



public space as well as a vehicular drop-off for the Portola Hotel and Monterey Conference Center. It must also provide a truck-loading location for the Conference Center and be both inviting and accessible to pedestrians from all four corners of the plaza.

# circulation, parking, & streetscape



Historically, this area was not a plaza but a city block

**Portola Plaza**

*Existing*





# circulation, parking, & streetscape

The plan for Portola Plaza, as illustrated to the right, is to direct vehicle access from Alvarado Street to Portola Circle. Pedestrian access surrounds the plaza.



# circulation, parking, & streetscape



*fountain elements*

The Portola Plaza fountain becomes a dynamic feature, formed of elegant materials and lighting, to complement the renovated Conference Center.



*truck loading*

# circulation, parking, & streetscape



*event tent*

*bus queue*

Moveable planters, kiosks and street furniture within the new Portola Plaza design allow for functional flexibility on Del Monte Terrace

# circulation, parking, & streetscape

The edges of the Portola Plaza should reflect and enhance the character of the plaza.



*existing storefronts*



*existing*



*storefronts more desirable to tenants*



*proposed*

# circulation, parking, & streetscape

## Alvarado Extension

Alvarado Mall serves as a vital link between the Downtown and the waterfront and should feel like a continuation of Alvarado Street. The objective of the Specific Plan is to increase activity through this space to a level that will activate the link between the Downtown and the waterfront. Although the mall should remain primarily a pedestrian thoroughfare, additional access for bicycles and trolleys would increase the level of activity that would draw more people between the City's two major destinations.



*existing*



*proposed*

# circulation, parking, & streetscape

Activation of the Alvarado Mall could include permitting MST trolleys, horse drawn carriages, parades, and street events.



downtown specific plan

# circulation, parking, & streetscape

## Custom House Plaza

Custom House Plaza is Monterey's "living room" where festivals and other key events are held. It is the primary gathering spot in the Downtown. The plaza is also a key connection between the Waterfront and the rest of Downtown, including Alvarado Street. In its current configuration, the plaza does not serve either of these functions well.

The existing plaza is uninviting and discourages pedestrians from entering or strolling through from either side. This is even more difficult during events. In addition, the space is less than ideal for many of the events that are held there.

By reusing the plaza's existing infrastructure and framework and redesigning the space to meet the functional needs of both pedestrians and events, the plaza can be efficiently resuscitated and transformed into an integral part of the Downtown experience for both locals and visitors.

When complete, the plaza should be more inviting to those who enter from either Alvarado Street or the Waterfront. It should guide them on a dramatic stroll through the plaza to their destination. A few key changes, including the addition of several new walls and ramps, a redesigned fountain and new paving, as well as an upgrade to the landscape and street furniture, can revitalize the entire plaza. Replacing the south and north steps with a gradual ramp will make it

a continuation of the new Alvarado Street (mall) design. Reestablishing a physical connection to Scott Street will further encourage circulation through the plaza.

Custom House Plaza will also need a convenient bypass to allow pedestrian flow during events. Subdividing the large plaza into smaller areas will facilitate more types of public and private events. The addition of plaza venues for private events can generate additional income to offset maintenance costs. In addition, the availability of more venues for break-out events could make the nearby Monterey Conference Center a more attractive choice for conference operators.

# circulation, parking, & streetscape



*Above: Existing Custom House Plaza*

*Below: Historic view of the Pacific House*



*Below: Historic view of termination of Calle Principal and Alvarado Street where Custom House Plaza exists today*





# circulation, parking, & streetscape



*Historically, this area was not  
a plaza the termination of Cale  
Principal and Alvarado Street*

**Custom House Plaza**

*Existing*



# circulation, parking, & streetscape

Custom House Plaza will contain a fountain circle, seating areas and programmable spaces, as illustrated on the following graphics.

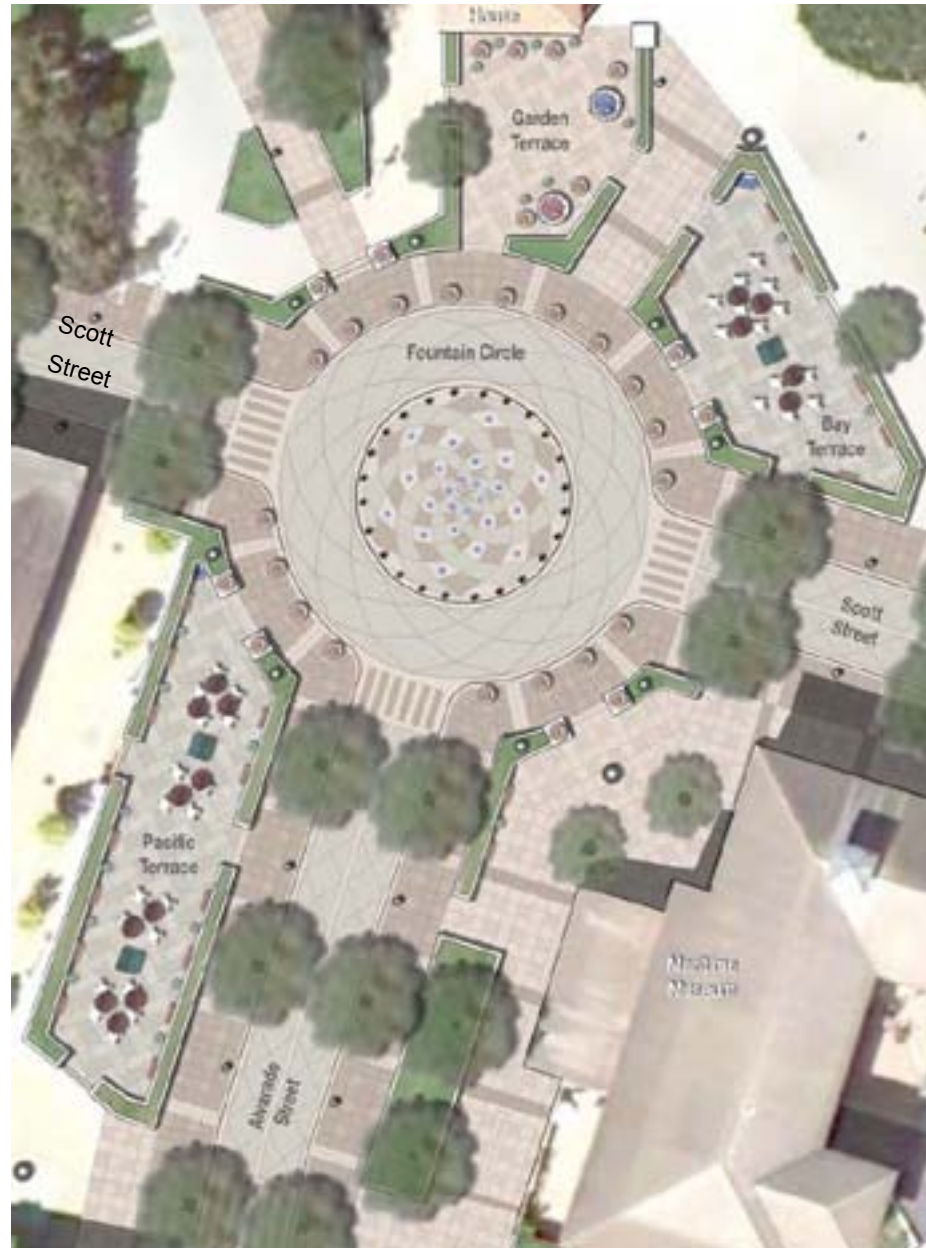

# circulation, parking, & streetscape



*automobile exhibits*



*booth events*

Custom House Plaza becomes a set of large and smaller terraces that can function independently or together, providing maximum flexibility.

# circulation, parking, & streetscape

The addition/relocation of walls will help redefine the Custom House Plaza



# circulation, parking, & streetscape

Redesign of fountain area  
in Custom House Plaza.



# circulation, parking, & streetscape



*180-seat event*



*small tent*

Moveable planters, kiosks, and street furniture allow for flexibility on all terraces in Custom House Plaza.

# circulation, parking, & streetscape



*1000-seat concert*



*500-seat event*

The dynamic center fountain can be turned off to expand the usable space in Custom House Plaza.

# circulation, parking, & streetscape



A custom tent utilizing light standards for quick installation could be used during various plaza events.





# circulation, parking, & streetscape



*existing*

A new fountain becomes the centerpiece for the Custom House Plaza. The fountain design will develop through a collaborative process that explores different types of fountain designs - dynamic, monumental, etc.



*new design*

# circulation, parking, & streetscape



## Custom House Plaza Features

- moveable planter bollards*
- amenities*
- public art*
- food kiosks*
- traditional lighting*
- street furniture*
- stone walls*
- temporary event fencing*

# circulation, parking, & streetscape

## Simoneau Plaza

If Custom House Plaza is Monterey's "living room," then Simoneau Plaza is the City's "family room." It is a more intimate setting for local resident-oriented events. The relocation of the transit station will free up this prime Downtown location to become a more functional and attractive destination.

The plaza should have the capacity for multiple civic events. These could include lunchtime concerts, seating for "pop-up" food vendors, tables for an evening wine and beer garden, and a winter ice rink - among many options.

The current plaza is elevated above street level, but should be lowered to a point halfway between the Munras Avenue high point and the Pearl and Tyler Streets intersection low point. Mid-block would now be at plaza level and provide service vehicle access. This creates easier access to and better visibility into the plaza.

The focal point of the plaza can be a dynamic fountain at its center, with dazzling lights throughout. The plaza can also provide a performance stage, concession kiosks, and a public restroom to support the many functions that will fill the plaza.

The Alvarado corner could be illuminated with features, such as "celebration lanterns," while the Munras-Tyler corner features a downtown gateway element.

The plan to convert Pearl Street between Alvarado and Tyler Streets into a bicycle boulevard further compliments the Simoneau Plaza plan.

# circulation, parking, & streetscape



**Simoneau Plaza**

*Existing*

# circulation, parking, & streetscape

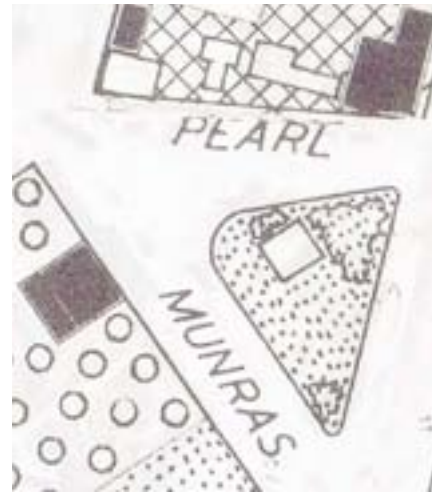

*historic plan*

**Simoneau Plaza**

*Existing*



# circulation, parking, & streetscape

## Simoneau Plaza

Simoneau Plaza will become a beautiful entry onto Alvarado Street. The plaza will be lowered to street grade. Amenities will be added such as trees, outdoor seating, and decorative features. The space can also be programmed.



# circulation, parking, & streetscape



Improved lighting, hardscape features and the addition of outdoor seating would greatly improve the activity of the plaza.



# circulation, parking, & streetscape



*shade sails*



*art shows*

The new plaza includes moveable planters, kiosks, and street furniture to allow for flexibility.



# circulation, parking, & streetscape



*350-seat concert*



*ice rink*

The new plaza plan includes a dynamic center fountain that can be turned off to expand the useable space.

# circulation, parking, & streetscape



New plaza features include...

- tables and chairs
- stone walls
- traditional and decorative lighting
- food kiosks

# circulation, parking, & streetscape

## Royal Presidio Chapel Plaza

A portion of Church Street leading to the chapel can be redesigned to function as a street as well as a plaza. A tree planting program and other streetscape improvements can be pursued for Figueroa Street that creates a connection between Del Monte Avenue and the Royal Presidio Chapel.



*plaza concept*



*existing*



*new design*

# circulation, parking, & streetscape

## Connecting the Plazas

One thematic idea to link plazas within the Downtown

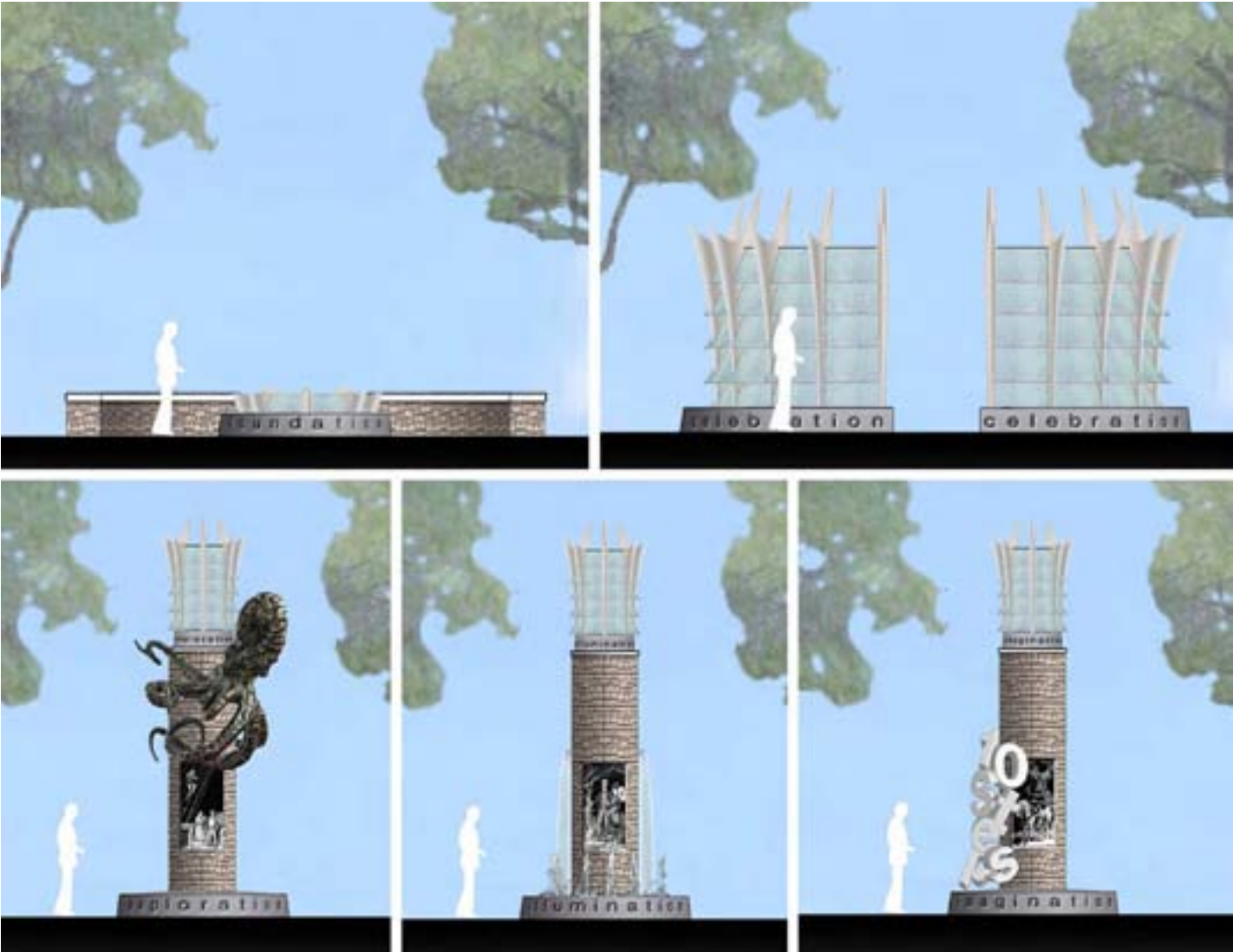

# circulation, parking, & streetscape

## WAYFINDING AND PUBLIC SIGNS

Downtown has a varied collection of public sign systems that do not always function as needed. Three different wayfinding systems direct drivers to various destinations, and yet another system is used to direct drivers to public parking. Two systems are used for pedestrian information, and another two systems used for historic markers.

The goal for Downtown wayfinding is to create a comprehensive coordinated sign program that addresses wayfinding, seasonal events, and sponsorship. These systems should be unified and simplified to provide a more informative, easy-to-read sign program, and should be designed to complement the street and plaza feature improvements, as well.

The following sign designs are examples of a themed wayfinding program that could be developed. The example includes destinations that are organized by area to simplify the information, with each area having a designated color.

Parking directional signs would clearly identify routes to the entrances of the public parking garages throughout Downtown. In addition, the signs could display the number of parking stalls available in each garage.

A new public sign program will coordinate the signs in Downtown Monterey creating a cohesive vision for the area.

### The Downtown Wayfinding System includes:

- Advanced Directional Vehicular Signs
- Lane Directional Signs
- Parking Directional Signs
- Pedestrian Directional and Informational Signs
- Information and Sponsorship Sign Kiosks
- Historic Markers



*existing signs - different systems are uncoordinated*

# circulation, parking, & streetscape



**Advanced Directional Vehicular Signs**

*One example of how new sign designs could adopt the traditional design of the existing streetlight standards.*

*The destinations are organized by area, each a different color to simplify the information.*



**Lane Directional Vehicular Signs**

# circulation, parking, & streetscape

## Parking Directional Signs

*Parking directional signs clearly identify routes to Downtown public parking garage entrances. These signs could also display the number of available parking stalls in each.*

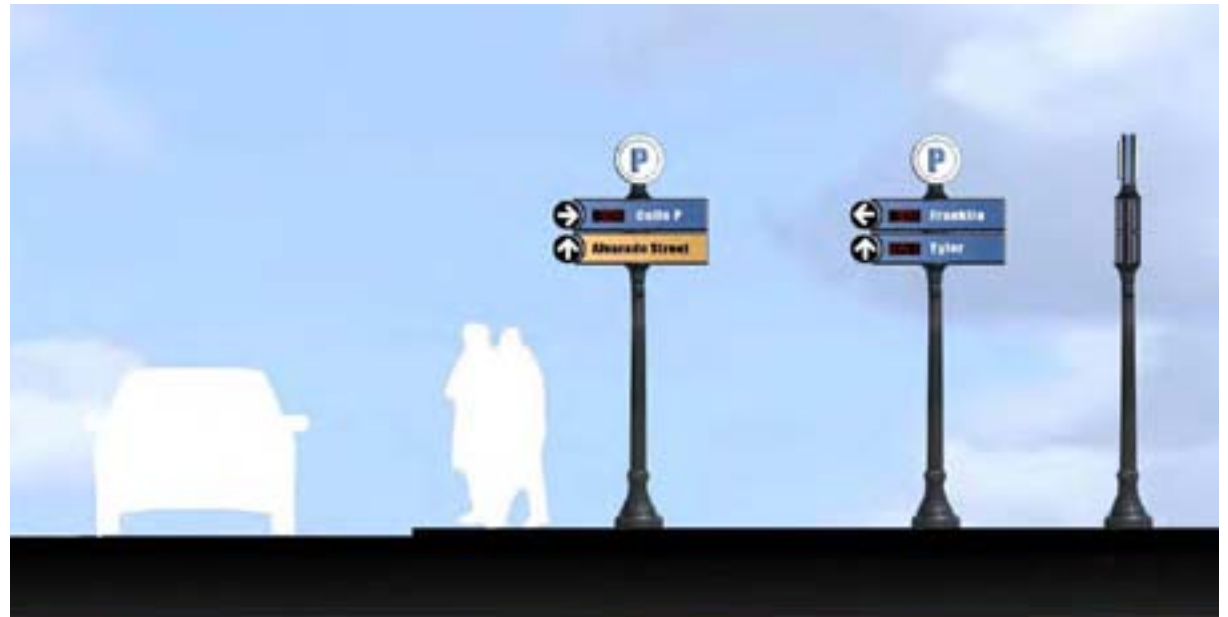

## Pedestrian Directional and Information Signs



# circulation, parking, & streetscape



Information and  
Sponsorship Sign Kiosks



Historic Markers



# circulation, parking, & streetscape

## SIGN AND LIGHT POLES AND FIXTURES

Public rights-of-way traffic control and lighting facilities serve three purposes: 1) to provide traffic signs and lights at appropriate locations, 2) to provide a safe level of light along the roadway, and 3) to provide a safe level of lighting along the sidewalk. The light pole and fixture design currently in use on Alvarado Street serve as the standard for future facilities. The existing facilities may be combined with upgraded cobra-style lights to add

additional light to the roadway, as necessary. Selecting a light pole and fixture already in use in Monterey will reduce long-term operational costs. New light poles and fixtures shall match the existing Downtown Monterey pole and fixture design.

The illustration below is an example of how a single design theme can apply to all sign and light poles and fixtures.



# circulation, parking, & streetscape

## Safety

Lighting should be at levels sufficient to enhance safety along streets and other outdoor spaces. This is especially important at intersections for pedestrian crossings. In mid-block street light conditions, there should be sufficient light for safety, but it may be less than that at intersections.

## Public Street Lighting Design Strategy

Three lighting types are to be used for street lights in the public realm, as well as lighting on private property that is visible from the public way. These are described in detail later in this section. The three types are:

1. Historic Alvarado Streetlight
2. Contemporary Crook-neck
3. Contemporary Cobra

The Lighting Design Strategy for street lights combines consideration of the National Historic Landmark districts and the Specific Plan Character Areas. These different street light areas are to be identified by their lighting design:

### Alvarado Character Area and the NHLs

The commercial core of downtown should be identified with the historic street light that is presently used on Alvarado Street. This corresponds to the Alvarado District character area. In addition, the same light

style should be used throughout the two NHLs (the Heritage District and the Island of Adobes District). This light style will be more compatible with the historic resources in these areas, particularly the adobes.

### Pearl District Lighting Strategy

While this area also is zoned commercial, it presently contains substantial amounts of residential buildings, mixed in with commercial uses. The intent is to provide a lower level of lighting intensity, while meeting safety needs, and to accommodate a gradual increase in density as redevelopment occurs. The contemporary street light design will be used, but it will be spaced more widely. A “contemporary” crook-neck fixture would be used in this area.

### East Village District Lighting Strategy

The East Village District is also a transitional area, with a mix of commercial and residential uses. The contemporary crook-neck fixture would also be used in this area.

### Pierce District Lighting Strategy

The Pierce District is primarily residential and institutional in its current uses. It serves as a transition to the residential neighborhoods to the west. The contemporary cobra style would be used in this area.



*The historic Alvarado street light, at the intersection of Munras and Pearl, in 1948. View looking south.*

# circulation, parking, & streetscape

## Summary of Street Light Fixture Applications

	Historic Type Light	Contemporary Crookneck	Contemporary Cobra	Bollard light
<b>Character Area</b>				
Alvarado	✓			
East Village		✓		
Pearl		✓		
Public Recreation		✓		
Heritage	✓			
Island of Adobes	✓			
Pierce			✓	
Royal Presidio		✓		
Friendly Plaza				✓

### Public Recreation District Lighting

The Public Recreation District lies between the Pearl District and the Alvarado District, with an edge along Del Monte. The contemporary crook-neck design should be used in this area, to link it with the Pearl and East Village areas. This style will also be compatible with light fixtures in the harbor area.

### Royal Presidio District

While the historic Alvarado street light would be compatible with the chapel, this is a small area, and it would be difficult to establish a distinct identity with only a few fixtures. It is more reasonable to continue the use of the crook-neck fixture in this area. Accent lighting on the building itself would help to identify the structure as an important historic resource.

### Representative Light Fixtures



Bollard light



Contemporary crookneck



Contemporary cobra



Representative types of historic light fixture with opaque cap

This series of street light fixtures shown above represent appropriate fixture types for downtown.

# circulation, parking, & streetscape

## Street Light Types Map

The map below identifies where the specific street light types are proposed.

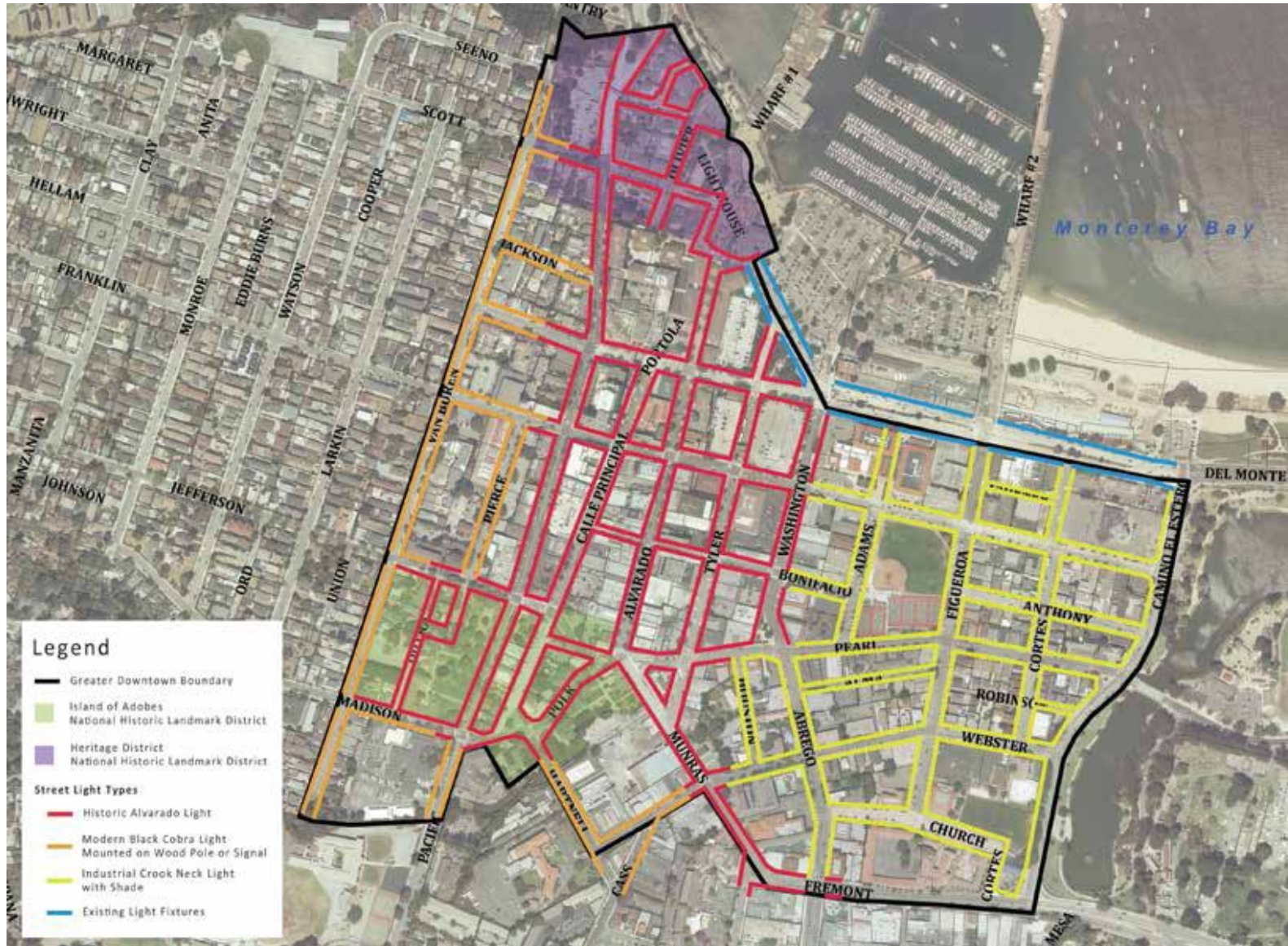

# circulation, parking, & streetscape

## Public Street Lights

The following specifications reflect the goal for public lighting to complement private site and building lighting, ensure even and shielded light sources and provide safety.

### Lighting Types General Principles

Three different types of street light designs will be used in the downtown. In all cases, the most current technology shall be used to shield and hide diodes so that they are not visible from the standpoint of pedestrians, vehicles and residences to the extent possible. Exact specifications are not provided due to continually advancing technology.

#### **Type 1: Historic (Alvarado) Street Light**

This light will identify the historic core and will draw upon the precedent of the fixture that presently exists on Alvarado. It would be installed throughout the Alvarado District character area, as well as in all portions of the two National Historic Landmark districts. This would have a black metal finish.

#### **Technical specifications for historic (Alvarado) street light:**

This historic fixture shall have an assembly that consists of a tapered, octagonal lamp housing. It is topped with an opaque cap, which terminates in a finial. The pole shall be cast metal, in a tapered fluted design with a flared, ornamental base.

Lamp: LED or Induction source

Light temperature: 2700K to 3700K range

Height of Pole: Maximum 15 feet, minimum to stay out or reach to prevent vandalism. Achieve a consistent height to ensure a rhythm of lights.

Location: Spacing of poles shall meet average maintained illuminance level: Maximum 1.0 footcandles with uniformity ratio of 6:1 to 3:1

All fixtures shall be equipped with a dimmer switch and set to the lowest setting for safety and visual consistency.



*A mix of light sources and colors exists on Alvarado. The relationship of street lights to buildings, in terms of color and means of illumination, are considerations. Historic street lights establish a distinct rhythm along the block, which contributes to a sense of visual continuity. The “cool” color of the lights, however, contrasts with the warmer lighting used on signs and buildings. A warmer color that complements product display would be preferred. Seasonal lighting wrapped on street trees adds another aspect to consider.*

# circulation, parking, & streetscape



*The cool color temperature of this street light contrasts with the warmer light used to illuminate building details and storefronts. An objective of street lighting is to complement retail display and nighttime activities, and therefore a warmer temperature is preferred.*

## **Type 2: “Contemporary Crook-neck down-light”**

The second street light design will be a simpler design, but still one that is distinct to the area in which it is used. This will be installed in the Pearl and East Village Districts. It is a shielded lamp, on a crook-necked arm, which keeps the light focused downward. This fixture is one that can be used on existing poles in the Pearl and East Village Districts, but later can be mounted on new poles as redevelopment in the area occurs and as the city’s policy of undergrounding power lines moves forward.

### **Technical specifications for contemporary down-light:**

Lamp: LED or Induction

Light temperature: 2700K to 3500K range

Height of Pole: 20 feet maximum

Location: Spacing to meet average maintained illuminance level: Maximum 1.0 footcandles with uniformity ratio of 6:1 to 3:1

## **Type 3: “Contemporary Cobra Light”**

This light would be used to supplement light levels at intersections where additional lighting is needed and where the lower-height Types 1 and 2 cannot meet the light level standards alone. It also would be used on existing poles in the Pierce District. It would have a black metal finish. Supplemental “Historic Type” fixtures may be used where additional pedestrian lighting is needed.

### **Technical specifications for contemporary cobra light:**

Lamp: LED or Induction

Light temperature: 2700K to 3500K range

Height of Pole: varies

Location: Spacing to meet the minimum horizontal and vertical illumination for vehicle and pedestrian safety

# circulation, parking, & streetscape

## PARKING

Managing parking has been shown to be the single most effective tool for managing congestion, even when densities are relatively low and major investments in other modes have not been made. Parking management can also have a significant impact on commute mode choice, which translates directly to reductions in auto congestion and improved livability of commercial districts and adjacent neighborhoods.

As Downtown Monterey continues to grow and evolve, its parking needs will change as well. This Plan identifies parking management techniques that address current challenges and can be adjusted to future needs. Above all else, these techniques are based on a parking management approach that will enable more efficient utilization of existing supply, while alleviating parking congestion. In recognition of these considerations, the following principles informed the development of parking management recommendations for the downtown community:

- Set clear parking priorities based on downtown's strengths and vision for the future
- Manage the entire parking supply as part of an integrated system
- Manage parking facilities with a focus on maintaining availability, not simply increasing supply
- Optimize investment in parking by making

efficient use of all public and private parking facilities and encouraging use of viable alternative mode options—before constructing new parking

- Use any potential parking revenue to fund transportation programs that maintain adequate parking supply and support use of alternative transportation options in the downtown area
- Use residential permit districts to address spillover concerns in residential neighborhoods
- Encourage economic revitalization and remove barriers to development and adaptive reuse projects by adopting parking standards that are tailored to the unique parking demands of mixed-use, walkable communities
- Ensure flexibility for developers by providing a variety of tools to meet and/or reduce parking requirements
- Provide flexibility to local decision makers and City staff to adapt to future changes in parking demand and travel patterns to maintain a 15% parking vacancy

# circulation, parking, & streetscape

## Recommended Parking Management Techniques

### Install Real-Time Availability and Wayfinding Signs

Real-time availability signs will be installed in the Downtown parking garages and the Waterfront lots, and will also be accessible online. These digital displays provide real-time information about available supply, serving to increase utilization of off-street facilities, maximizing efficiency, and reducing cruising for available on-street spaces. This strategy also enables information sharing via the web and mobile devices, allowing residents and visitors alike to access real-time parking data from home or on their smart phone.

Wayfinding signs to major parking facilities (Downtown parking garages, Waterfront lots, and public lots) should be installed at key locations downtown (e.g. on Del Monte Avenue as a visitor approaches downtown). Such a strategy will direct visitors to underutilized off-street facilities, especially if located at the traditional entrances to downtown, near major garages and attractions, and along major arterials. Improved wayfinding with new signs can help direct motorists to their desired destination and is another way to help eliminate traffic caused by cars cruising for parking.





# circulation, parking, & streetscape

## Implement Valet and Tandem Parking

The City should allow valet and tandem parking in the Downtown parking garages and Waterfront lots during peak summer weekends. Valet parking can maximize off-street lot and garage spaces for long-term parkers such as employees, thereby freeing up more convenient curb spaces for visitors. Technology exists to make the car retrieval process customer-friendly. In addition, tandem parking could be used for employees in the Waterfront lots during summer weekends and in

the Downtown parking garages both during summer weekends and when demand peaks. This strategy will increase the supply of parking downtown and is particularly effective when arrivals and departures are regular, such as an employee arriving and leaving his or her place of work. Another benefit of this strategy is that it facilitates compact development, freeing underutilized surface parking lots for new development.



# circulation, parking, & streetscape

## **Install Parking Meters where Necessary and Adjust Off-Street Prices Accordingly**

The City should install on-street parking meters in the downtown areas that exceed an 85% on-street occupancy rate. Parking prices should be set at rates that create a 15% vacancy rate on each block and eliminate time limits during allowable parking hours. On-street rates can be raised or lowered based on future occupancy counts. Simultaneously, off-street public garage and lot rates should be reduced and adjusted based on their occupancy levels. This pricing structure will encourage long-term parkers, such as employees and all-day visitors to take advantage of under-utilized off-street spaces while freeing on-street spaces for higher turnover motorists. Once the pricing structure has been implemented, dedicate parking revenues to public improvements and public services.

## **Create a Residential Parking Benefit District**

Residential Parking Benefit Districts in adjacent residential areas can be implemented at the same time that parking meters are implemented for curb parking in the downtown core. These Districts can be implemented, as necessary, once a parking evaluation has taken place.

Residential Parking Benefit Districts are similar to residential parking permit districts, but allow a limited number of commuters to pay to use surplus on-street

parking spaces in residential areas and return the resulting revenues to the neighborhood to fund public improvements.



# 08 Public Utilities

This page left intentionally blank

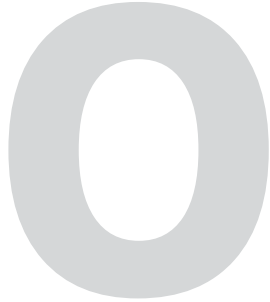

## Public Utilities

### IMPROVEMENT REQUIREMENTS

#### Sanitary Sewer Collection System

For Citywide repairs, the City is pursuing Clean Water State Revolving Fund Program funding to design and construct necessary system-wide sanitary sewer collection system rehabilitation projects. Engineering evaluations of the condition of this aged system have prompted the need for its rehabilitation. The improvements include the repair or replacement of 886 sanitary sewer collection system structures located within the street right-of-way and/or City easements. With its citywide scope, this project's improvements include sanitary sewer collection system rehabilitation in the Planning Area.

#### Storm Drainage and Low Impact Design

General Plan Safety Element Policy c.4. requires project designs to: (1) maximize the amount of natural drainage that can be percolated into the soil, and (2) minimize direct overland runoff onto adjoining properties, water courses, and streets. This approach to handling stormwater reduces the need for costly storm drainage improvements, which are often miles downstream. Building coverage and paved surfaces must be minimized and incorporated within a system of porous pavements, ponding areas, and siltation basins.

ROW design strategies to minimize runoff by slowing, spreading, sinking, and capturing rain water are known as LID best management practices (BMPs). LID BMPs manage the volume and rate of storm water runoff flowing away from a site and assist in maintaining a more natural hydrologic process in urban watersheds.

Storm water design requirements for public and private development projects, such as LID, are mandated by the State through the City's Phase II municipal storm water permit. These requirements will be changing in 2013 when the Regional Board is anticipated to revise existing storm water design requirements for development.

Along with many other components, improvements to the public ROW must consider storm water drainage and management, including permit mandates that require LID and hydromodification be a part of designs. Preliminary GIS soil investigations of the Downtown area show that the existing soil substrate is not well-suited for LID design strategies to slow, sink, and spread storm water at development sites. Site-specific engineering and soil field investigations and analyses will be necessary and required to confirm this potential for drainage design purposes.

This page left intentionally blank

# 09 financing & implementation

This page left intentionally blank



# financing & implementation

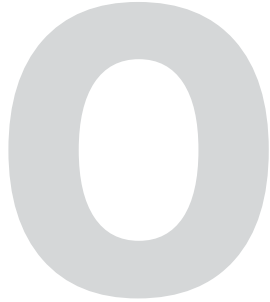

## Financing and Implementation Strategy

### PURPOSE OF THE STRATEGY

Specific plans are required to set forth implementation and financing measures. An effective implementation strategy outlines how the goals of the specific plan are to be accomplished, while still providing flexibility to adapt to ongoing evolution of market conditions and opportunities for particular projects.

This implementation strategy assesses the types of development opportunities that will be allowed by the Specific Plan, including catalyst projects. It identifies implementation challenges that will need to be addressed, and recommends potential actions to address them.

### DEVELOPMENT OPPORTUNITIES

Limited water availability will constrain development to a lesser amount than could be supported by current and future market conditions. The Downtown Specific Plan envisions up to 260 new dwelling units, and up to 50,000 square feet of new commercial space. The commercial space would allow a mix of retail uses, including specialty grocery, drug stores, other specialty retail, and office and services uses.

Most of this new development is envisioned to be in mixed-use buildings, with ground floor commercial space and for-sale or rental residential on upper stories. Buildings would be up to four stories total in the Downtown area. Mixed-use development is likely because it can better support high land values and better utilizes limited sites in the area.

The relatively modest amount of new development in the area means that redevelopment and re-tenanting of existing properties will be as significant a factor in the future evolution of the area. Redevelopment of existing properties can include changes in use, e.g. conversion of obsolete upstairs office space into new residential units or retail space, within an existing building. Re-tenanting presents an opportunity to replace underperforming retailers as leases expire with new retailers that can enhance the appeal of an area as a shopping destination.

# financing & implementation

## OPPORTUNITY SITES

The first phase of Downtown development may include the following projects, which are currently being processed for entitlements, and have sufficient water availability for their intended uses:

- 595 Munras – mixed-use development with ground floor commercial and affordable residential above.
- 426 Alvarado – development of ground floor retail space, with the potential inclusion of residential units above.
- 459 Alvarado - development of a mixed-use project with ground floor retail and restaurants, and residential above.

Additional potential opportunity sites for a second phase of future mixed-use development, for which there are no proposed development plans at this time, could include:

- 100 Del Monte (redevelopment of a three-story building)
- 401 Alvarado (redevelopment of one-story commercial buildings)
- 200 Franklin (full Downtown block with two buildings, large surface parking)

This list of opportunity sites does not preclude additional new development on other sites, or redevelopment of existing properties, if those sites possess a sufficient existing water allocation, or can transfer an allocation from adjacent parcels if the properties are combined

under single ownership. This constraint will remain in place until such time as additional water resources are obtained.

These opportunity sites could potentially result in an addition of just over 200 dwelling units and nearly 100,000 square feet of commercial space. The development in both phases and its resulting net increase in commercial space would likely utilize the available water rights for additional commercial development. There would potentially remain sufficient water for an additional 60 dwelling units.

See graphics in Chapter 4: Challenges & Opportunities for maps of opportunity sites.

# financing & implementation

## PUBLIC IMPROVEMENTS

A series of streetscape and infrastructure improvements have been identified to enhance the appearance and functioning of the Downtown area, in order to support existing businesses as well as enhance the potential for new development and redevelopment of existing buildings in the area. Public investment in improvements to streets and public property can be a key factor for stimulating private investment and reducing the risk associated with development.

Some of the key improvements in the Downtown area include the conversion of most streets to two-way circulation (including traffic signal and associated improvements) and improvements to Alvarado Street to enhance it as the “Main Street” for Downtown. The cost of these improvements means that they will likely need to be phased in over a number of years. In order to maximize the potential for public improvements to leverage private investment, the phasing and location of improvements should to the greatest extent possible be matched to areas that have the strongest potential for private development.

A first phase of near-term new projects in the Downtown area may include the proposed mixed-use project at 459 Alvarado Street, the Regency Theater mixed-use project at 426 Alvarado, and a mixed-use project with ground floor retail and affordable residential above at 595 Munras Avenue. A subsequent phase of new projects could include redevelopment of the building

at 100 Del Monte Avenue, along with redevelopment of opportunity sites identified during the Specific Plan process, such as the block bounded by East Franklin, Tyler, Washington, and Bonifacio Place; and sites on the south side of East Franklin Street between Alvarado and Tyler Streets.

## IMPLEMENTATION CHALLENGES AND CITY ACTIONS

The implementation of the Specific Plan will face a number of challenges, and the City will need to take an active role in addressing these challenges for successful plan implementation to occur.

### Elimination of Redevelopment

The elimination of redevelopment has both taken away a primary funding source for revitalization (through tax increment finance) and eliminated the City’s organizational capacity for land acquisition and assembly, public-private partnership development, and design and implementation of public improvements. Consideration is underway within the City on how to replace these lost capacities, as well as in the State Legislature on how to create successor funding mechanisms that can support revitalization, affordable housing, and other projects.

While there is no clear answer at this time, for the implementation strategy it is reasonable to assume that

# financing & implementation

between new State authorities and City action there may emerge in the near-term a successor entity(ies) and funding tools that can assist with affordable housing production, public improvements, public-private partnerships, and other actions to support new development. However, this successor(s) may have diminished capacities and funding compared to the previous redevelopment agency.

## Parking

Parking requirements have a substantial impact on project feasibility, both because they reduce the amount of space that can be built on a site and because of the cost of construction for underground or above-ground parking when it is required. This is particularly the case for Downtown sites, where small parcels require the provision of underground parking. The high cost of underground parking, up to \$45,000 per space, can make market-rate projects with rental residential units infeasible.

The City has a proposed policy for the Downtown to unbundle parking from rental rates for residential projects in order to promote use of alternative modes of transit. Downtown residents would pay to obtain a monthly parking permit in public garages. Shared parking between projects would also be encouraged, with no parking requirements for retail. This policy can enhance the feasibility of projects. At the same time, projects should retain the ability to provide on-site parking where it is necessary (e.g., with for-sale residential).

## Retail Recruitment Strategy

The Downtown Monterey Retail Repositioning Strategy prepared by the Monterey Commercial Property Owners Association highlighted the need to strengthen the retail mix in the Downtown area, and introduce new retail choices, in order to enhance it as a shopping destination for both residents and visitors.

The strongest retail districts have a combination of independent retailers who can provide a unique identity and ambiance, along with regional and national retailers who can provide a diverse and attractive retail mix. Other retail districts, such as Downtown Davis, California, have successfully pursued retailer recruitment strategies to attract new types of retail uses and specific retailers. The City should work with the Monterey Commercial Property Owners Association on the development and implementation of such a strategy.

## Water Availability

The lack of sufficient available water allocation for new development, and the inability to efficiently reallocate existing water allocations among properties, are the greatest impediments to new development in the Downtown. Water availability is a critical regional issue, one that is currently being addressed by the City and other Monterey Peninsula and area jurisdictions.

# financing & implementation

## Funding Public Improvements

There are a variety of financing tools available to cover the cost of City actions and public improvements. The City is in the process of formulating a long-range capital improvement program (CIP). Besides the types of public improvements identified for the Specific Plan, the City faces the need to finance public improvements in other areas of the City, renovation of facilities and areas that are key for tourism, and a generalized need for repairs and rehabilitation of aging roads and other infrastructure.

As part of the long-term CIP development, the City is currently looking at phasing options for spreading public improvement work over the next 20 years, as well as evaluating a full range of financing options. This will include engagement of a public finance advisor for development and review of options.

The outcome of the CIP development and evaluation of financial alternatives will be the formulation of a City-wide strategy for addressing its wide-ranging public improvement needs. As part of this process, a financing plan will be developed for Downtown improvements that identifies both the timing and sources of funding for the work. The range of funding sources for the Specific Plan funding strategy would be expected to choose from the following as well as other sources:

***Tax Increment Finance / Infrastructure Finance District.*** While redevelopment agencies and their project areas have been eliminated (including the City's), the remaining tax increment finance tool still available under State law is the creation of Infrastructure Finance Districts. The current statute is difficult to use, involving County and school district concurrence and a vote, although it has been used in a couple areas by the City of San Francisco. Proposals to streamline its use have been advocated in order to enhance its ability to support local economic development.

Use of tax increment does not affect current agency budgets or impose additional costs on developers or property owners. Rather, it uses the incremental growth in property tax revenues to help fund the cost of public improvements. Whether existing or future statutes are used, it should be expected that the available amount would be only the City's share of new tax increment, i.e. the County and school districts would capture their share of all new tax increment (this would be potentially one-third or less of the amount that was previously captured by redevelopment). Tax increment proceeds can be used to finance bonds, although in the early years internal City loans may be needed until the increment grows sufficiently to cover bond debt service.

***Assessment Districts.*** There are a large variety of assessment districts authorized by California law, ranging from Community Facilities Districts to Landscape and Lighting. A Business Improvement

# financing & implementation

District (BID), such as the Cannery Row Business Improvement District, is a type of assessment district that can assess either business owners or property owners (or both) to fund promotional, marketing, and other activities including additional maintenance or other services or improvements.

The type of assessment district that is used needs to be matched to the types of improvements and operating activities to be funded. The general approach of an Assessment District is to levy a tax surcharge on all properties within a defined district to finance identified benefits. Most districts require a vote under Proposition 218 for their creation and periodic renewal.

**Development Impact Fees.** This would involve a modification of the City's existing development impact fee schedule to raise additional funds to offset the cost of impacts specifically attributable to the new development envisioned by the Specific Plan (under State law, impact fees cannot be used to fund existing deficiencies in public infrastructure or services). A nexus study would be required to document the appropriateness of any increases.

**Developer Exactions.** For projects where discretionary City approval is required, the City can enter into a development agreement that outlines additional payments and improvements that would be made by a developer. For example, a development agreement could help fund a street improvement. The potential amount that can be raised by exactions is

limited to projects where development agreements are required, and the amount that a project can contribute without impacting its economic feasibility.

**Public-Private Partnerships.** Public-private partnerships can take several forms. One form is where the City uses its land, or other contributions to projects, to enter into a partnership with a developer. The resulting project creates public benefits that would not otherwise be possible for the public sector because of financing provided by the private sector (affordable housing, additional parking, desired new facilities, etc.) and also enables a developer to build a project that it could not otherwise do through use of publicly owned sites, enhanced economic feasibility, etc.

Another type of partnership is Owner Participation Agreements. These were previously used by Redevelopment Agencies to provide technical assistance to property owners to help them understand options for improvements and redevelopment. This approach can be used by the City as needed to help property owners, with the benefit that subsequent redevelopment creates new tax increment, impact fees, and other fiscal revenues.

**Revenue Bonds.** Public improvements that generate ongoing revenue streams, such as parking garages, can be financed through revenue bonds. The most likely funding source for such a bond would be reallocation of existing parking revenues and fines and/or an increase in these revenues from higher charges.

# financing & implementation

**General Fund Debt Obligations.** New and redeveloped commercial and lodging projects can generate significant growth in property taxes, sales taxes, and transient occupancy (room) taxes that benefits the City's General Fund. The amount of the growth in General Fund revenues from these sources can be used to fund debt-service on tax-exempt debt obligations to fund the cost of improvements. While a flexible source, such bonds require a two-thirds vote of local residents for approval.

**Federal, State & Regional Grant Programs.** Besides the above local sources, there are a wide variety of grant sources, many of which are transportation-related, that flow from the federal government to states and regional bodies such as AMBAG and TAMC. The uses of these funds include: enhancement of transit and alternative modes of travel (both bicycle and pedestrian); economic development; environmental enhancement; and funding of other public facilities. These grants are typically awarded on a competitive basis, and often require a 20 percent local matching contribution. The recently passed federal MAP-21 transportation bill has consolidated and revised a number of federal grant programs, and agency guidance will be issued in the near-term that provides more details on which types of projects will be funded in the future.

# financing & implementation

## CAPITAL IMPROVEMENT PROGRAM

The specific plan process has identified the potential in the Downtown area for up to 260 new dwelling units and 50,000 square feet of new commercial space. These figures represent development that is possible based upon the existing available water allocation for new development. Other existing properties can support new development, or redevelopment for new uses to the extent that their existing water allocation supports it. Besides development, there is also the potential for re-tenanting of existing buildings to expand retail and service offerings in the Downtown area.

A series of opportunity sites have been identified in both the Downtown area that have the potential to enhance retail and residential choices. These sites would utilize most of the available water allocation for new development, leaving the potential for additional dwelling units. Other implementation actions that can enhance the feasibility of these projects include proposed parking policies that reduce parking requirements and allow off-site parking. Pursuing a Downtown retailer recruitment strategy can help improve shopping choices and enhance its attractiveness as a destination for both residents and visitors.

A program of public improvements has been formulated for the Downtown area that will enhance streetscapes and benefit existing and new businesses, improve traffic circulation, and address other infrastructure needs. In the Downtown area, most streets will be

converted to two-way circulation, and Alvarado Street will be enhanced as Monterey's "Main Street."

Financing public improvements is a key challenge that has increased in difficulty due to the elimination of redevelopment agencies by the State. The City is in the process of formulating a long-term Capital Improvement Program that incorporates both public improvements for the Specific Plan as well as the City's other extensive requirements for repairs, rehabilitation, and other improvements. A financing plan for Specific Plan improvements will be based upon the City-wide Capital Improvement Program financing strategy that will be developed.



10 administration

This page left intentionally blank

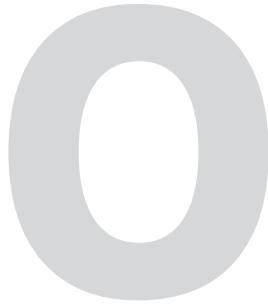

## Administration

This chapter details the development review procedures for projects within the Planning Area. The Specific Plan serves as the guide for design and development of the Planning Area. Deviation from the Design Guidelines outlined in Chapter 5 may be proposed when alternative design approaches are introduced that are found to be consistent with the Vision and Goals listed in Chapter 2 and the design objectives listed in Chapter 5.

Where the Specific Plan falls silent on any particular topic, City policies and ordinances, such as the City of Monterey General Plan, Monterey City Code, and other City laws and policy documents shall apply.

### PURPOSE AND INTENT

This Specific Plan is intended to streamline the approval process for development of the Planning Area. Projects that are consistent with the development standards and design guidelines of this plan will be reviewed at a staff level, in conjunction with the adopted environmental review as required under the California Environmental Quality Act (CEQA). Projects that are required to obtain a use permit or are inconsistent with the development standards and/or design guidelines will be referred to the Planning Commission or Architectural Review Committee according to Monterey City Code Article 25.

### AMENDMENTS TO THE SPECIFIC PLAN

Over time, various sections of the Specific Plan may need to be revised to respond to changing economic or political conditions. Any amendment to the Specific Plan shall follow Government Code procedures (Sections 65453, 65454, and 65456), or, alternatively, local procedures for administrative amendments as described in this chapter. Furthermore, the proposed Specific Plan amendment must be consistent with the goals, policies, and programs of the City of Monterey General Plan.

Amendments to the Specific Plan will fall under one of two categories, (1) administrative amendments and (2) other amendments, and will follow a separate process as discussed below. A decision as to which category an amendment falls under shall be made at staff level.

### Administrative Amendments

Administrative amendments to the Specific Plan are considered minor revisions and do not require formal approval by the Planning Commission or City Council. Administrative amendments do not deviate from the overall vision and plan of the Planning Area. Examples of administrative amendments include, but are not limited to minor text changes, corrections and/or updates to existing conditions information, and other relatively minor changes that do not materially change the nature or intent of the Specific Plan such

# administration

that it would constitute a change in land use, result in a new environmental impact, or adversely affect the economic development goals of the City.

Administrative amendments shall be considered for approval and are subject to a 10 day appeal period after being publicly noticed by posting a notice on the City Hall and Monterey Library bulletin boards and providing a notice to all property owners within the Planning Area (via mail or email). All appeals to administrative amendments shall be considered for approval by the Planning Commission and further appealable to the City Council.

## Other Amendments

Other amendments to the Specific Plan are considered significant revisions and require formal approval by the Planning Commission and City Council, per Government Code procedures (Sections 65453, 65454, and 65456). Examples of other amendments include, but are not limited to changes to the land use plan, permitted uses, circulation and streetscape improvements, and/or substantive changes to the development standards.

## DEVELOPMENT REVIEW PROCESS

This section establishes the procedural and content requirements for the review and approval for development occurring within the Planning Area. It is the intent of this section to provide clearly defined procedures for the streamlined review of such

development, while insuring consistent implementation of the development standards and design guidelines for each character area.

All development within the Planning Area must proceed through a review process. The review process is intended to encourage site development which respects the overall vision of the Planning Area. The development review process shall determine development consistency with the following components of this Specific Plan:

- Land Use, Development, and Design Objectives, Standards and Guidelines (Chapter 5)
- Circulation, Parking, and Streetscape Plan (Chapter 6)
- Public Utilities Plan (Chapter 7)

Development review for all new development and redevelopment within the Planning Area is a two level process. Review shall begin at the Tier One review level and if deemed necessary, a Tier Two review will follow. Both levels are follows:

***Tier One Review.*** Tier One development review is an administrative (staff level) process, and is applicable to projects that meet the Specific Plan's objectives, development standards, and design guidelines. Tier One review allows City staff to make a final consistency determination on development projects, which will streamline and simplify the approval process. If a

project is not determined to be consistent with each of the Specific Plan elements as noted above, it is subject to a Tier Two review. Furthermore, if a project requires a Use Permit, subdivision, or Historic Permit per the development standards or the zoning ordinance, as applicable, then a Tier Two review will be required.

***Tier Two Review.*** Tier Two development review requires review and approval by the City Planning Commission, Architectural Review Committee, and/or Historic Preservation Commission. Tier Two review is applicable to projects that require conditional approval, or that deviate from the prescribed development standards and design guidelines.

## IMPLEMENTATION

### Administration and Enforcement

It shall be the duty of the Planning Director to enforce the provisions as set forth in the Specific Plan. All officers, employees, and officials of the City of Monterey who are vested with the duty or authority to issue permits or licenses shall ensure that the project complies with the provisions of this Specific Plan. Any permit, license or approval issued that is in conflict with the requirements of this Specific Plan shall be reconsidered.

### Relationship to Zoning Code

The provisions contained in this Specific Plan constitute the primary land use and development standards for the project area. Where provisions are not addressed

in this Specific Plan, regulations as described in the Monterey City Code shall apply.

### Severability

If any portion of the Plan is, for any reason, held invalid by a court of competent jurisdiction, such portion shall be deemed a separate, distinct and independent provision and the invalidity of such provision shall not affect the validity of the remaining portion of the Plan.

This page left intentionally blank

11 definitions

This page left intentionally blank





## Definitions

**Alteration:** Any act or process, except repair and light construction that changes one or more of the architectural features of a structure or site, including, but not limited to, the erection, construction, reconstruction, relocation of, or addition to a structure.

**Amplified Music/Sound:** The use of any indoor or outdoor amplified, sound or entertainment that is audible from the exterior of a building, from a separate tenant space, or an adjacent property, including but not limited to the use of speakers, microphones, amplifiers, acoustic instruments or the human voice. This category does not include those devices exempt pursuant to MCC Chapter 22-17.8.

**Appropriate:** In some cases, a stated action or design choice is defined as being “appropriate” in the text. In such cases, by choosing the design approach referred to as “appropriate”, the reader will be in compliance with the Guideline.

**Assembly, Minor:** Includes the following-

Small Instructional Service: An establishment offering classes or educational training to groups of five or fewer students in a single classroom or studio environment. Examples include musical instruction, academic tutoring, and similar uses.

Large Instructional Service: An establishment offering classes, educational training, or other instructional services to groups of six to nineteen students in a single classroom or studio environment. Examples include group exercise training, driving instruction schools, and similar uses.

**Assembly, Major:** Includes the following-

Small Group Assembly: An establishment offering entertainment, social exchange, religious services, educational training, or other instructional services to groups of twenty to forty-nine persons in a single room. Examples include performance venues, movie theaters, religious institutions, community centers, college or university extension programs, group addiction services, social clubs, community centers, or similar uses.

Large Group Assembly: An establishment offering entertainment, social exchange, religious services, educational training, or other instructional services to groups of fifty or more persons in a single room. Examples include performance venues, movie theaters, religious institutions, community centers, college or university extension programs, group addiction services, social clubs, community centers, or similar uses.

**Balusters:** Small, upright posts that support a railing.

**Character-Defining Features:** Character refers to all those visual aspects and physical features that comprise the appearance of an historic building related to descriptions of property types and styles. Character-defining elements include the overall shape of the building, its materials, craftsmanship, and decorative details, as well as the various aspects of its site and environment.

**Compatibility:** Designing new buildings or alterations that fit in the context of the historic neighborhood,

# definitions

related to application of design guidelines/criteria, for alterations and new construction. Some elements of compatible design are: keeping a sense of human scale, using building features and materials of a familiar dimension, such as traditional brick, to maintain the visual continuity in the neighborhood.

**Conjectural:** The replacement or reconstruction of missing building parts and details must be based on physical evidence, historic photographs or writing and not upon conjecture.

**Consider:** When the term “consider” is used, a design suggestion is offered to the reader as an example of one method of how the Design Guideline at hand could be met.

**Cornice:** The continuous projection at the top of a wall. The top course or molding of a wall when it serves as a crowning member.

**Contributing Property:** A contributing property is any building, structure, object or site within the boundaries of a historic district which reflects the significance of the district as a whole, either because of historic associations, historic architectural qualities, or archaeological features. Another key aspect of the contributing property is historic integrity.

**Dark Sky:** International Dark – Sky Association

**Food and Beverage Sales, Major:** Includes the following-

Convenience Store with Beer and Wine Sales: An establishment that contains 5,000 square feet or

less of gross floor area and sells food and beverages primarily for consumption off premises, including beer and wine. Operates with a Type 20 Alcohol Sales License.

Convenience Store with Beer, Wine, and Distilled Spirit Sales: An establishment that contains 5,000 square feet or less of gross floor area, and sells food and beverages primarily for consumption off premises, including beer, wine and distilled spirits. Operates with a Type 21 Alcohol Sales License. Includes Liquor Stores.

Grocery Store: An establishment that contains more than 5,000 square feet of gross floor area and sells food and non-alcoholic beverages primarily for consumption off of the premises and small recycling facilities within convenience drop off zones, as defined by the California Beverage Container Recycling and litter reduction.

Grocery Store with Beer and Wine Sales: An establishment that contains more than 5,000 square feet of gross floor area, sells food and beverages primarily for consumption off of the premises, including beer and wine. Operates with a Type 20 Alcohol Sales License.

Grocery Store with Beer, Wine, and Distilled Spirit Sales: An establishment that contains more than 5,000 square feet of gross floor area and sells food and beverage primarily for consumption off of the premises, including beer, wine and distilled spirits. Operates with a Type 21 Alcohol Sales License.

# definitions

**Food and Beverage Sales, Minor:** An establishment that contains 5,000 square feet or less of gross floor area and sells food and non-alcoholic beverages primarily for consumption off premises.

**Foot-candle:** one foot-candle is equal to one lumen per square foot or approximately 10.764 lux.

**Form:** The overall geometric shape of a structure (i.e., most structures are rectangular in form).

**In-kind:** A process of rehabilitation utilized only where materials are extensively deteriorated or damaged and cannot be repaired. Deteriorated materials or features are repaired with the same materials. This process is based on physical evidence of essential form and detailing of historic materials or features. (Related to Replacement and Repair)

**Integrity:** The retention of sufficient aspects of location, design, setting, workmanship, materials, feeling or association for a property to convey its historic significance. A majority of the resource's structural system and materials and its character defining features should remain.

**K:** Kelvins, a unit of measurement for temperature.

**Lamp:** The light source.

**Luminaire:** A complete lighting unit, consisting of one or more lamps (bulbs or tubes that emit light), along with the socket and other parts that hold the lamp in place and protect it, wiring that connects the lamp to a power source, and a reflector that helps direct and distribute the light.

**Non-contributing Resource in an Historic District:** Those properties that do not have historic significance are termed "non-contributing." The reasons for this designation could be that it is of more recent construction; it is an older property that has lost its integrity, or there is insufficient information to determine that the property has historic significance.

**Motor Vehicle Sales and Rental:** An establishment that offers the sale or rental of new or used automobiles, trucks, recreational vehicles, trailers, boats or other vehicles licensed by the Department of Motor Vehicles. Motor vehicle services may be permitted as an ancillary use.

**Outdoor Sales:** The retail sales or rental of any merchandise where the gross floor area of the outdoor storage area exceeds 10% of the gross floor area of the enclosed building.

**Park and Recreation Facilities,** Park and recreation facilities and support uses (parking, snack bars, etc.).

**Parking Area, Private:** An area used for the parking of motor vehicles, boats or trailers by persons in residence or employed upon the premises.

**Parking Area, Public:** An area, other than a street or other public way, used for the parking of automobiles and available to the public for a fee, free of charge, or as an accommodation for clients or customers.

**Parking Subgrade:** Parking under a structure that is below the finished grade of the site.

**Residential, Minor:** Includes up to two dwelling units

# definitions

on a distinct parcel.

**Residential, Major:** Includes the following-

Multi-Unit Residential: Three or more dwelling units on a distinct parcel.

Single Room Occupancy Facility: The use of a building, structure, or property that offers four or more units that are defined and regulated as Single Room Occupancy units.

Single Room Occupancy Unit: A residential unit that consists of a sleeping/living room, is part of a multi-unit building, lacks individual cooking and/or bathroom facilities, is rented separately and where the tenant maintains sole right of access and control of the unit.

**Retail Sales, Minor:** An establishment that primarily offers new or used goods for purchase by the consumer of such goods, excluding other such establishments more specifically described herein. This use category includes vehicle sales if such a use is conducted completely within an enclosed building and does not include outdoor display of vehicles.

Retail Sales, Minor excludes the following:

Adult Content Sales: An establishment having as all or a significant portion of its stock books, magazines or other periodicals, films, videotapes, video discs or other such electronic, magnetic, or other means of creating a moving image upon any screen, television or other device, peep shows or other similar devices for use in individual viewing of films on the

premises, which books, magazines, periodicals, films, videotapes, video discs, or other means, peep shows or similar devices are substantially devoted to the depiction of sexual activities or specified anatomical areas as defined herein.

Animal Sales: Retail sales of small animals typically considered pets

Motor Vehicle Rental: An establishment that offers the rental of new or used automobiles, trucks, recreational vehicles, trailers, boats or other vehicles licensed by the Department of Motor Vehicles. Excludes Motor Vehicle Services.

Fuel Sales: An establishment offering the sale of motor fuel for any motor vehicle. Includes gas stations.

**Restaurant, Minor:** Includes the following-

Restaurant: An establishment that sells food and non-alcoholic beverages for consumption on the premises.

Convenience Restaurant: A restaurant or similar establishment offering food and/or beverages for sale for consumption on or off the premises in disposable containers and from a counter.

Restaurant with Beer and Wine Sales: An establishment that sells food, beer and wine for consumption on the premises and does not contain a bar area. Operates with a Type 40, 41, 42, or 75 Alcohol Sales License.

# definitions

Restaurant with Bar: Minor: An establishment that sells food, beer and wine for consumption on the premises and contains a bar area that occupies 25% or less of the restaurant area with no more than twenty seats. Operates with a Type 40, 41, 42, or 75 Alcohol Sales License.

**Restaurant-Major:** Includes the following-

Restaurant with Bar, Major: An establishment that sells food, beer, wine, and distilled spirits for consumption on the premises and contains a bar area that occupies more than 25% of the restaurant area and more than twenty seats. Operates with a Type 47 Alcohol Sales License.

Bar: An establishment that sells beer, wine or distilled spirits for consumption on the premises and without obligatory food service. Operates with a Type 48 or 61 Alcohol Sales License.

Night Club: An establishment that sells beer, wine or distilled spirits for consumption on the premises without obligatory food service and offers live entertainment. Operates with a Type 48 or 61 Alcohol Sales License.

Social Club with Bar: An establishment occupied by a fraternal, veterans, or similar membership-based organization that sells beer, wine and/or distilled spirits to members and guests only for consumption on the premises. Operate with a Type 51, 52, or 57 Alcohol Sales License.

**Seating, Outside, Incidental:** Seating area not

exceeding 150 square feet in size.

**Seating, Outside, Major:** Seating area over and above 150 square feet in size.

**Service, Minor:** Includes the following-

Bank, Retail: Financial institutions that provide retail banking services to individuals and businesses. This classification includes only those institutions engaged in the on site circulation of cash money and includes on or off-site automatic teller machines.

General Service: An establishment offering the direct provision to the customer of personal services including barber and beauty shops, seamstresses, tailors, shoe repair shops, dry cleaning (excluding processing plants), photocopying, mail and packing service centers, self-service laundries, appliance repair, and massage establishments.

Professional Office, Off-site: An establishment offering indirect provision of services on behalf of customers that do not visit the site to receive the service including remote medical or dental laboratories, testing facilities, escort services, telephone call centers, catering services apart from restaurants, and similar uses that do not provide in-person service or interaction with the ultimate recipient of the service.

Professional Offices: An establishment consisting of offices providing professional services directly to a customer. This includes architectural or engineering firms, computer software consulting, data

# definitions

management, financial services, interior design, graphic design, real estate, insurance, legal offices, medical/dental offices, on-site medical or dental testing, travel services, and title offices.

**Shielding:** The part of the fixture that blocks or controls light direction

**Story:** The portion of a building included between the upper surface of any floor and the upper surface of the floor above. The topmost story shall be the portion of a building included between the upper surface of the topmost floor and the ceiling or roof above. If a room, cellar, or unused under-floor area has more than 40% of the perimeter of the building over four feet above grade measured to the finished floor level above or is more than 12 feet at any point measured to the finished floor level above, it shall be considered the first story.

**Temporary Use:** A use, conducted outdoors or within a completely enclosed building for a period of time, not to exceed 90 consecutive days during any given year.

**Utility-Major (also Major Utility):** Includes a public or privately-owned or operated generating plant, electrical substation, above-ground electrical transmission line, switching building, refuse collection, PWS facility, processing, recycling or disposal facility, water reservoir or similar water storage facility, flood control or drainage facility, water or wastewater treatment plant, transportation or rail facility, and similar facilities and the following-

Personal Wireless Service (PWS) Facility: A facility for the provision of PWS, as defined in 47 U.S.C.

Section 332(c)(7)(C)(ii). (Ord. 3443 § 4, 2010; Ord. 3278 §1, 5/00)

**Utility-Minor:** Utility facilities that are necessary to support legally established uses and involve only minor structures such as electrical distribution lines and underground water and sewer lines.

## **Visitor Accommodation Facility:**

Visitor Accommodation, Major: Any building, portion of any building, or group of buildings in which there are guest rooms or suites, including housekeeping units, for transient guests where lodging with or without meals is provided. Visitor accommodation facilities are those required to pay transient occupancy tax by Article 3, Chapter 35 of this code. Visitor Accommodation - Major includes hotels, motels, beds and breakfast inns, and youth hostels.

Visitor Accommodation, Minor: A facility resulting from the conversion of single-family residences to country inns or bed and breakfast types of use, whereby limited numbers of visitors may obtain accommodations and a single meal upon the premises. Such legally permitted facility must present unique historical and/or architectural feature(s).

This page left intentionally blank

